

TOSHIBA Bipolar Linear Integrated Circuit Silicon Monolithic

TA8429H, TA8429HQ

Full-bridge Driver (H-Switch) for DC Motor (Driver for Switching between Forward and Reverse Rotation)

The TA8429H/HQ is a full-bridge driver IC for brush motor rotation control. Four operating modes are selectable from forward, reverse, stop and brake.

The TA8429H/HQ is best suited to drive medium-sized DC and bipolar stepping motors.

Since the motor drive section and control section have separate power supply pins, the TA8429H/HQ also allows servo control.

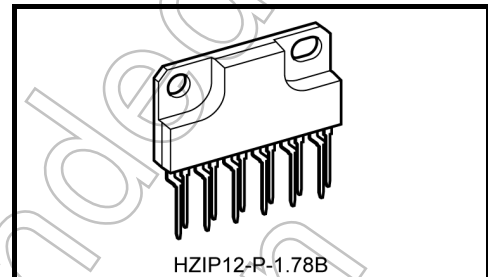

Weight : 4.04 g (typ.)

Features

- Output current of up to 3.0 A (AVE.) and 4.5 A (PEAK)
- Four different modes (forward rotation, reverse rotation, stop, and brake) are supported.
A counter-electromotive force absorber diode is also incorporated.
- Stand-by mode available: $I_{ST} \leq 100 \mu\text{A}$
- Built-in thermal shutdown and short circuit protection circuits
- HZIP power package sealed
- Wide range of operating voltage: $V_{CC} = 7 \text{ to } 27 \text{ V}$
 $V_S = 0 \text{ to } 27 \text{ V}$
*Please consider the internal loss (V_{sat}) to operate the IC though minimum V_S is defined zero.

Terminals of TA8429 written below are sensitive to electrostatic discharge. When handling this product, ensure that the environment is protected against electrostatic discharge by using an earth strap, a conductive mat and an ionizer. Ensure also that the ambient temperature and relative humidity are maintained at reasonable levels.

Terminals which are sensitive to electrostatic discharge: No. 1, 2, and 12.

The IC should be installed correctly. Otherwise, the IC or peripheral parts and devices may be degraded or permanently damaged.

The TA8429HQ is a Sn-plated product. (The Pb-containing materials with a high melting point that are exempted from RoHS directives are used inside the IC.)

The following conditions apply to solderability:

*Solderability

1. Use of Sn-37Pb solder bath
 - *solder bath temperature = 230°C
 - *dipping time = 5 seconds
 - *number of times = once
 - *use of R-type flux
2. Use of Sn-3.0Ag-0.5Cu solder bath
 - *solder bath temperature = 245°C
 - *dipping time = 5 seconds
 - *the number of times = once
 - *use of R-type flux

Block Diagram

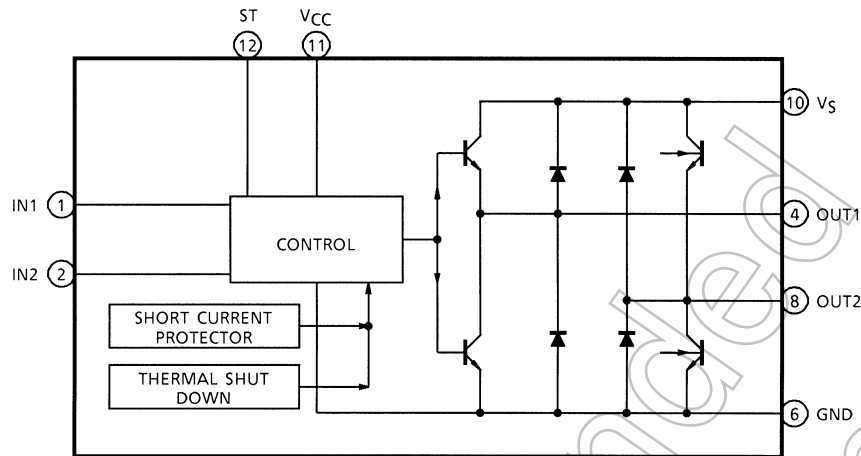

Pin Function

Pin No.	Symbol	Functional Description
1	IN1	These pins receive inputs for controlling the state of the outputs. The input sections incorporate a PNP-type voltage comparator.
2	IN2	
3	N.C	Non-connection
4	OUT1	This pin connects to a DC motor. It has a current carrying capacity of 3 A in both sink and source modes. A diode for absorbing counter-electromotive force in the motor is incorporated on both V _{CC} and ground sides.
5	N.C	Non-connection
6	GND	GND terminal
7	N.C	Non-connection
8	OUT2	This pin, along with pin 4, connects to a motor. It has the same function as pin 4. Its state is controlled with inputs to pins 1 and 2.
9	N.C	Non-connection
10	V _S	Supply voltage terminal for motor drive
11	V _{CC}	This is a supply voltage pin for the control section. It is completely separated from V _S .
12	ST	When this pin is open or connected to a ground, the current flowing through the motor is minimized (100 μA).

How Multi-Protection Works

The TA8429H/HQ incorporates two protection functions: over-current (ISD) and overheat (TSD).

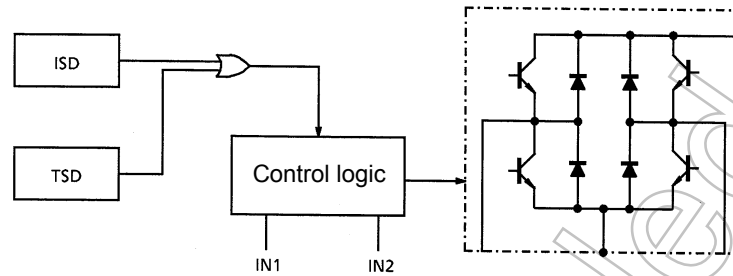

Note 1: These protection functions are only a means of temporarily avoiding some output short circuits or other abnormal conditions and are not guaranteed to prevent damage to the IC.

Note 2: If used under conditions where the absolute maximum ratings are exceeded, the IC may break down before the protection circuits start operating.

Overheat Protection (TSD)

- **Basic operation**

The input signal of the IC controls the output while the junction temperature (chip temperature) of the IC is equal to or lower than the TSD detection temperature. If the junction temperature becomes higher than the TSD detection temperature, the output enters a high-impedance state regardless of the level of the input signal.

- **Explanation of the operation**

The junction temperature is detected by monitoring the V_F of a diode on the chip. When the V_F becomes lower than the internal reference voltage, the control logic is directed to turn off the output transistor. While the V_F is higher than the reference voltage, the input signal at pins 1 and 2 controls the logic section.

Not Recommended for New Design

Over-current Protection (ISD)

• Basic operation

When the output current (pin 4 or 8, that is, I_{sink} or I_{source}) is equal to or lower than the ISD detection current, the input signal controls the output. If the output current exceeds the detection current, it changes to a switching waveform shown in Figure 1.

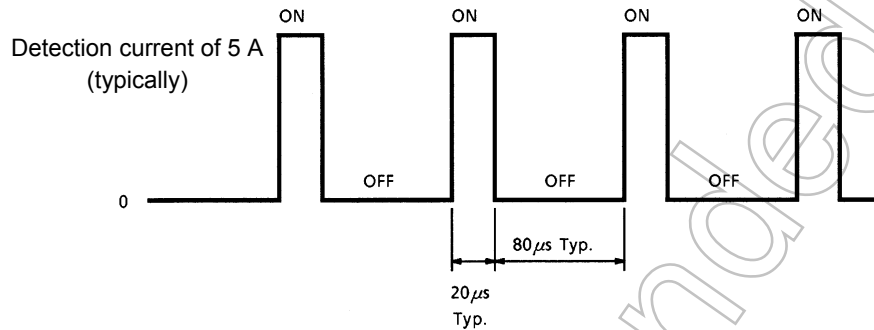

Figure 1 Basic operation

• Explanation of the operation

The output current is detected by monitoring the V_{BE} of each output transistor. A detector element is connected to each output transistor and to a short-circuit prevention circuit. If a current higher than the ISD detection current flows through one of the four output transistors, the short-circuit prevention circuit starts operating. This circuit incorporates a timer. If the over-current mode lasts for 20 μs (typically), the output is switched to the high-impedance state. It returns to the ON mode in 80 μs (typically). If the IC is still in the over current mode, the switching mode stated above is repeated until the IC is released from the over-current mode.

This circuit cannot limit all types of over current. If the outputs are short-circuited to each other or to a ground, the IC may break down before the protection circuit starts operating. Therefore use a resistor or fuse in the supply voltage (V_S) line.

Internal Circuit

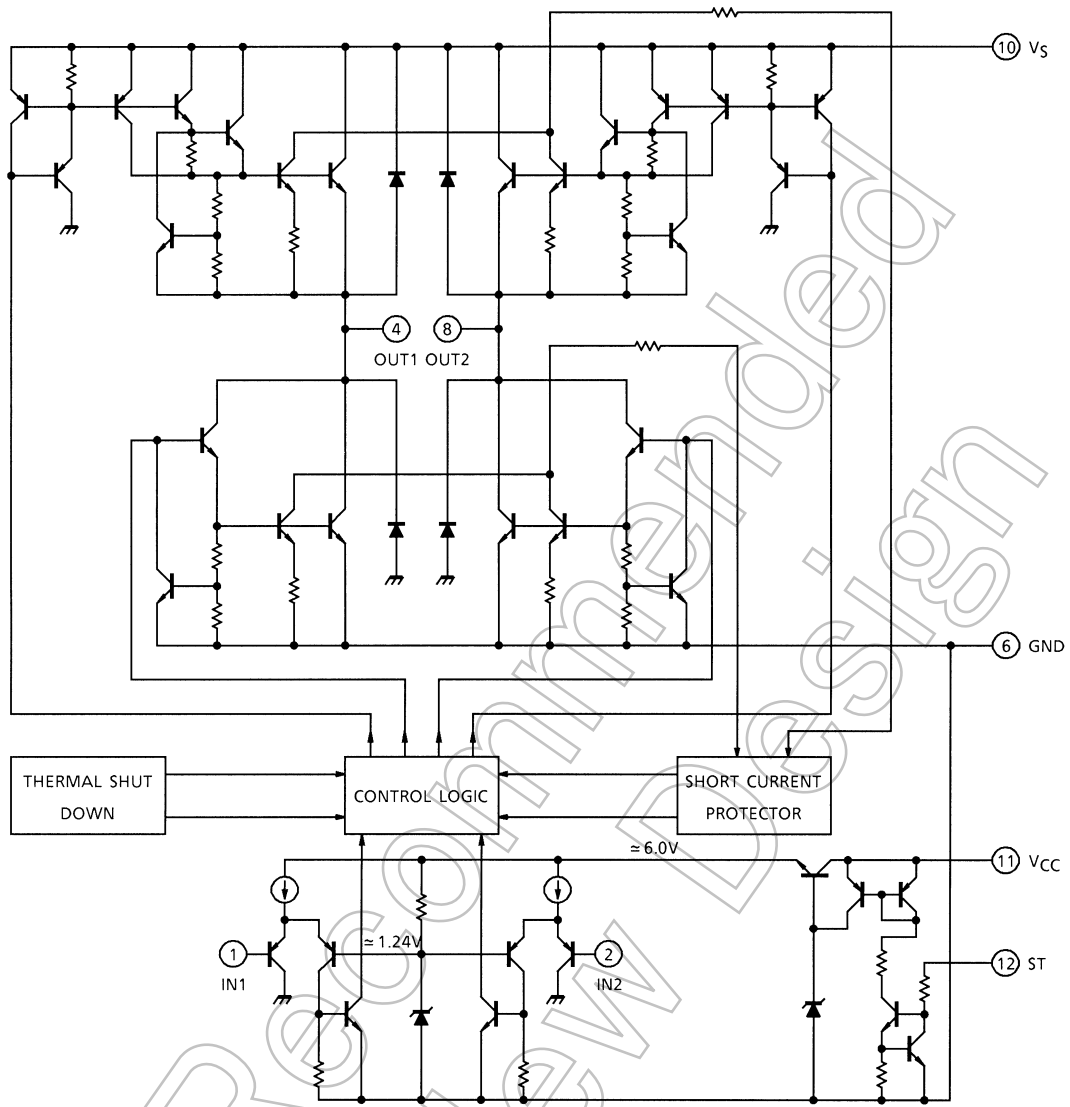

Function

Input		ST	Output		Mode
IN1	IN2		OUT1	OUT2	Motor
H	H	H	L	L	Short brake
L	H	H	L	H	CCW (CW)
H	L	H	H	L	CW (CCW)
L	L	H	OFF (high impedance)		Stop
H/L	H/L	L	OFF (high impedance)		Stand-by

Absolute Maximum Ratings ($T_a = 25^\circ\text{C}$)

Characteristics		Symbol	Rating	Unit
Supply voltage		V_{CC}, V_S	30	V
Input voltage		V_{IN}	-0.3 to V_{CC}	V
Output current	AVE.	I_O (AVE.)	3.0	A
	PEAK	I_O (PEAK)	4.5 (Note 1)	
Power dissipation		P_D	2.25 (Note 2)	W
			21.6 (Note 3)	
Operating temperature		T_{opr}	-30 to 85	$^\circ\text{C}$
Storage temperature		T_{stg}	-55 to 150	$^\circ\text{C}$

Note 1: $t = 100$ ms

Note 2: No heat sink

Note 3: $T_C = 85^\circ\text{C}$

Electrical Characteristics ($V_{CC} = 24$ V, $V_S = 24$ V, $T_a = 25^\circ\text{C}$)

Characteristics	Symbol	Test circuit	Test Condition	Min	Typ.	Max	Unit
Quiescent current (I) (V_{CC} Line)	I_{CC1}	1	Stop mode	—	6	12	mA
	I_{CC2}		Forward/reverse mode	—	20	40	
	I_{CC3}		Brake mode	—	20	40	
Quiescent current (II) (V_S Line)	I_{S1}	1	Stop mode	—	3	8	mA
	I_{S2}		Forward/reverse mode	—	16	40	
	I_{S3}		Brake mode	—	3	8	
Input voltage	V_{INL}	2	—	—	—	0.8	V
	V_{INH}		—	2.0	—	—	
Input current	I_{INL}	2	$V_{IN} = \text{GND}$	—	—	12	μA
	I_{INH}		$V_{IN} = V_{CC}$	—	—	10	
Output saturation voltage (Note)	V_{sat1}	3	$I_O = 1.5$ A	—	2.1	2.8	V
	V_{sat2}		$I_O = 3.0$ A	—	3.3	4.1	
Output leakage current	I_{LU}	4	$V_L = 25$ V	—	—	50	μA
	I_{LL}		$V_L = 25$ V	—	—	50	
Diode forward voltage	V_{FU}	5	$I_F = 3.0$ A	—	5.0	—	V
	V_{FL}		$I_F = 3.0$ A	—	1.5	—	
Thermal shutdown circuit operating temperature	T_{SD}	—	—	—	150	—	$^\circ\text{C}$
Stand-by current	I_{ST}	1	—	—	—	100	μA
Propagation delay time	t_{pLH}	2	—	—	1	—	μs
	t_{pHL}	2	—	—	1	—	

Note: Upper and lower side total

Test Circuit 1

I_{S1} , I_{S2} , I_{S3} , I_{CC1} , I_{CC2} , I_{CC3} , I_{ST}

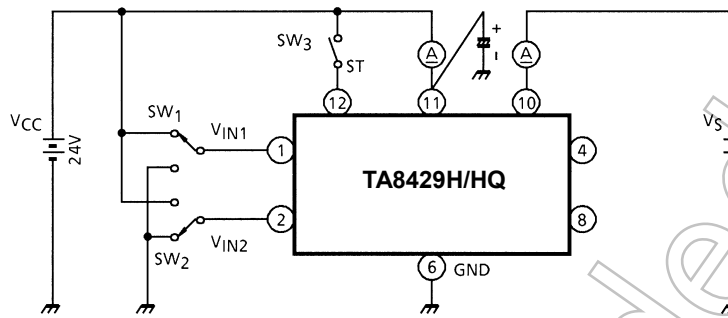

Test Circuit 2

V_{INH} , V_{INL} , I_{INH} , I_{INL} , t_{pHL} , t_{pLH}

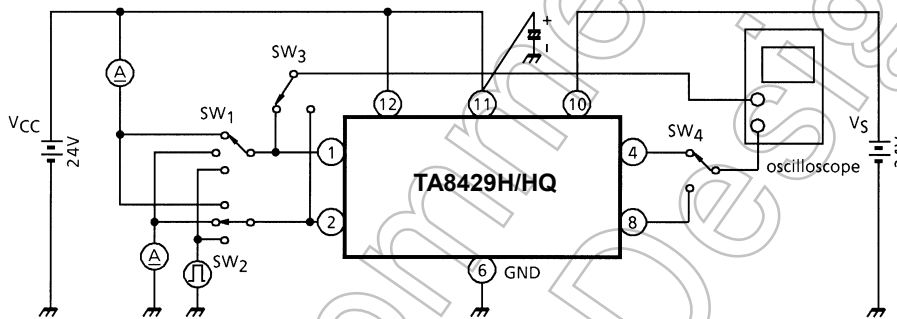

Test Circuit 3

V_{sat}

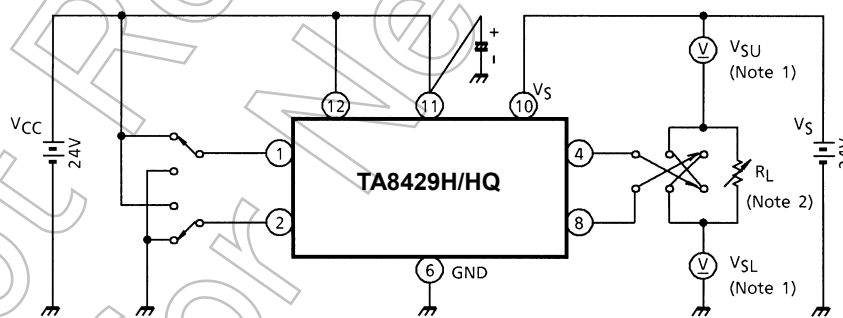

Note 1: $V_{sat} = V_{SU} + V_{SL}$

Note 2: Calibrate I_O to 1.5/3.0 A by R_L

Test Circuit 4
 I_{LU} , I_{LL}

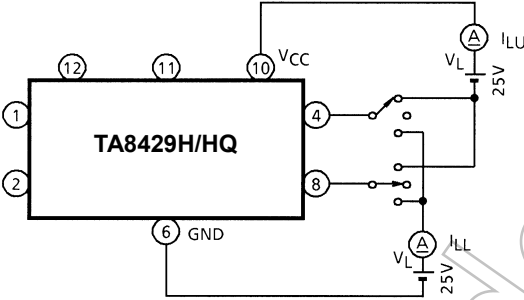

Test Circuit 5
 V_{FU} , V_{FL}

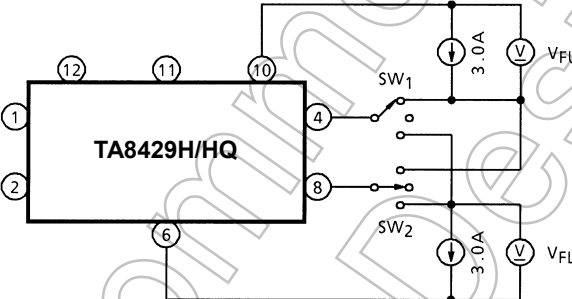

Not Recommended for New Design

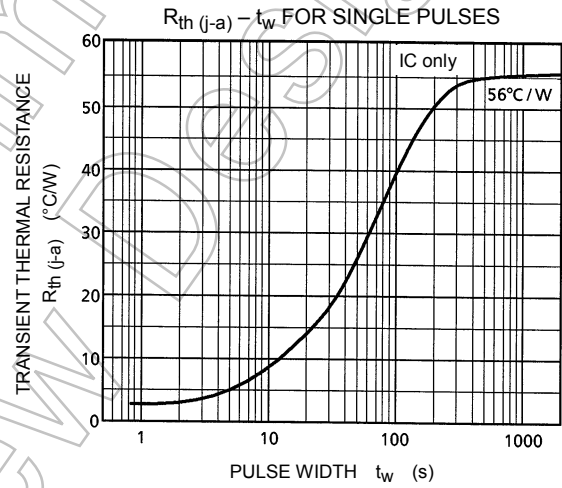
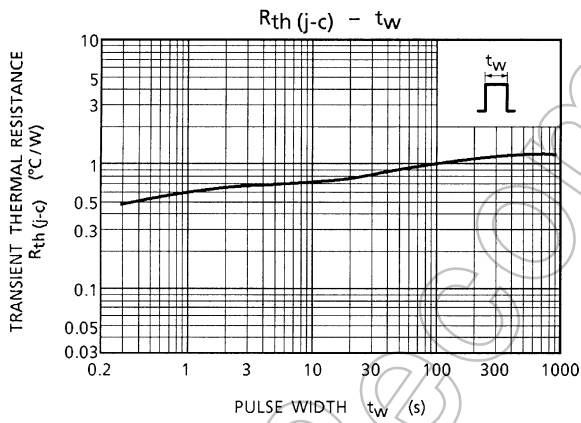
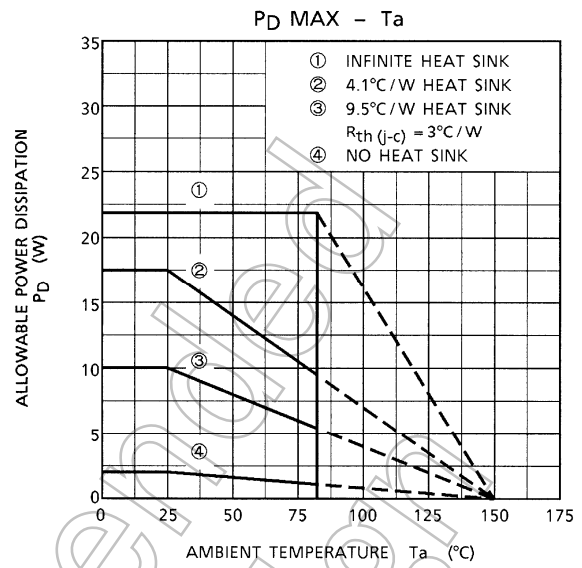
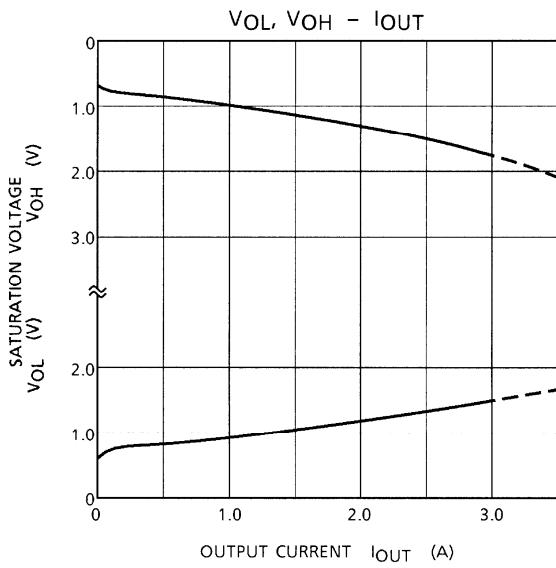

Application Circuit 1

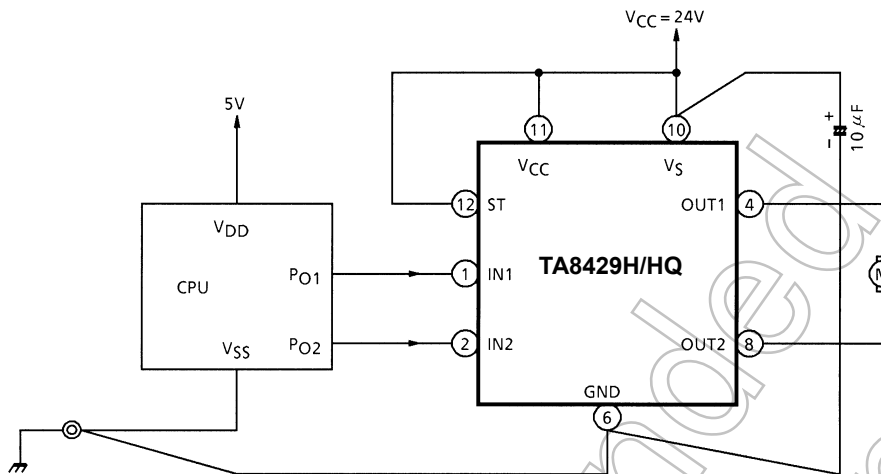

Application Circuit 2 (Separated standby function)

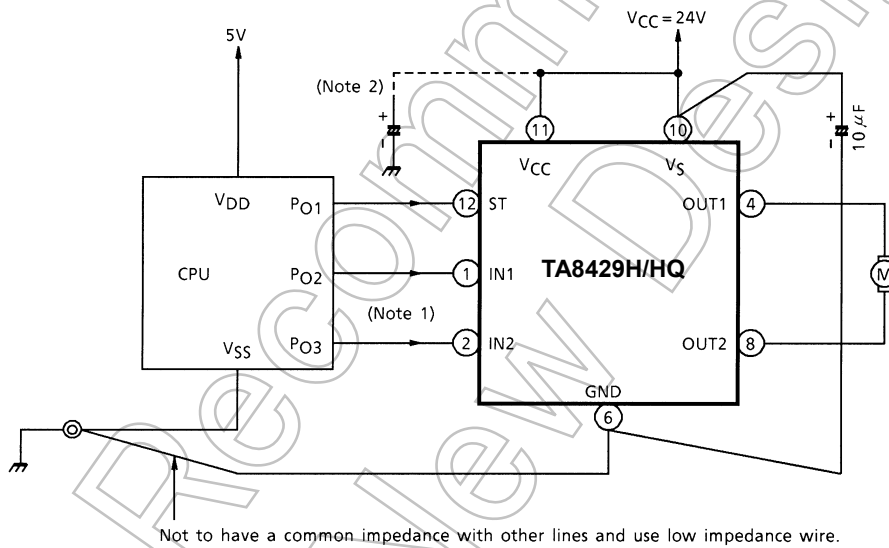

Note 1: Insert OFF-TIME (100 μ s or more) when the input signal is switched (between forward and reverse rotation and between forward/reverse rotation and brake).

Note 2: Connect if required.

Note 3: When turning on the power (V_{CC}/V_S), keep both IN1 and IN2 on a low level. Do not switch the inputs (IN1/IN2) before the V_{CC}/V_S reaches its rated value (as shown in Application Circuit Example 1). If the ST pin is connected to a CPU (Application Circuit Example 2), turn on the power while ST, IN1, and IN2 are kept on a low level. After this, switch the ST/IN1/IN2.

Note 4: Utmost care is necessary in the design of the output, V_{CC} , and GND lines since the IC may be destroyed by short-circuiting between outputs, air contamination faults, or faults due to improper grounding, or by short-circuiting between contiguous pins.

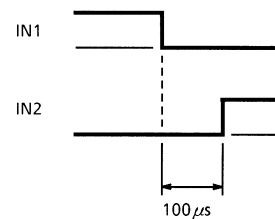

Package Dimensions

HZIP12-P-1.78B

Unit: mm

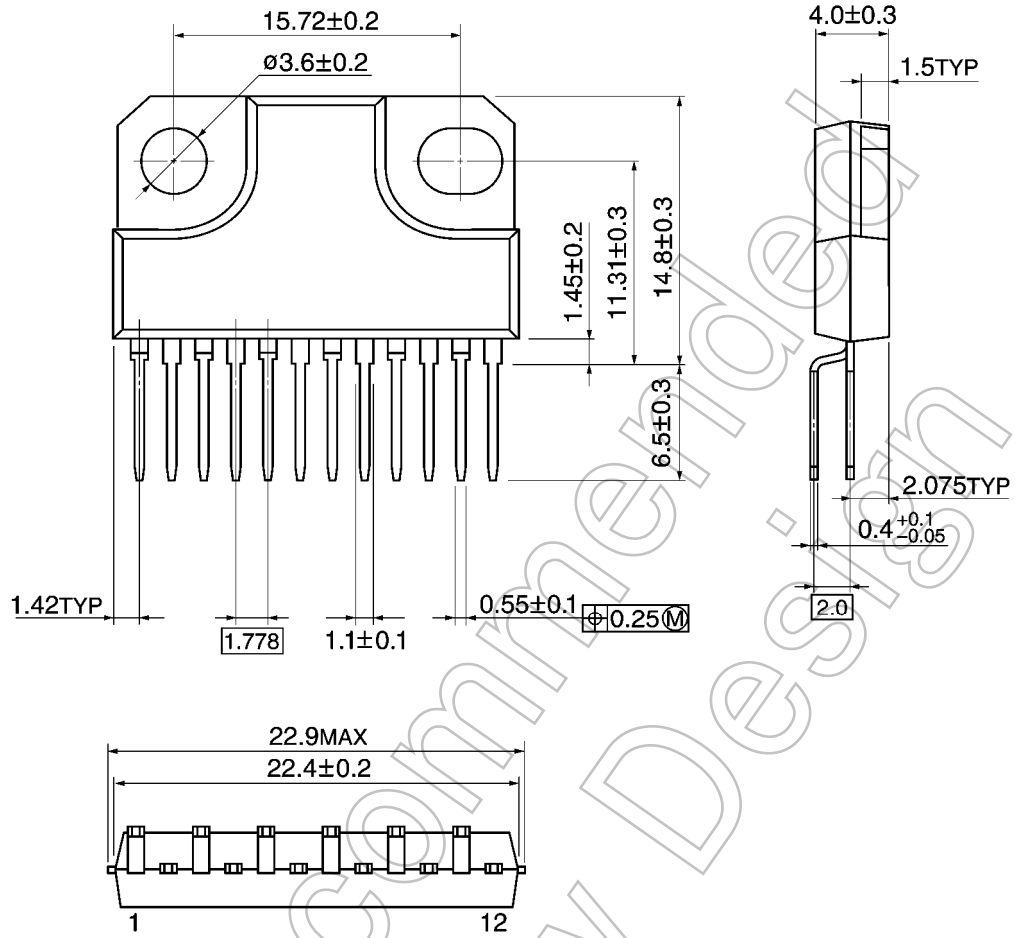

Weight: 4.04 g (typ.)

Not Recommended for New Design

Notes on Contents**1. Block Diagrams**

Some of the functional blocks, circuits, or constants in the block diagram may be omitted or simplified for explanatory purposes.

2. Equivalent Circuits

The equivalent circuit diagrams may be simplified or some parts of them may be omitted for explanatory purposes.

3. Timing Charts

Timing charts may be simplified for explanatory purposes.

4. Application Circuits

The application circuits shown in this document are provided for reference purposes only. Thorough evaluation is required, especially at the mass production design stage.

Toshiba does not grant any license to any industrial property rights by providing these examples of application circuits.

5. Test Circuits

Components in the test circuits are used only to obtain and confirm the device characteristics. These components and circuits are not guaranteed to prevent malfunction or failure from occurring in the application equipment.

IC Usage Considerations**Notes on handling of ICs**

- [1] The absolute maximum ratings of a semiconductor device are a set of ratings that must not be exceeded, even for a moment. Do not exceed any of these ratings.
Exceeding the rating(s) may cause the device breakdown, damage or deterioration, and may result injury by explosion or combustion.
- [2] Use an appropriate power supply fuse to ensure that a large current does not continuously flow in case of over current and/or IC failure. The IC will fully break down when used under conditions that exceed its absolute maximum ratings, when the wiring is routed improperly or when an abnormal pulse noise occurs from the wiring or load, causing a large current to continuously flow and the breakdown can lead smoke or ignition. To minimize the effects of the flow of a large current in case of breakdown, appropriate settings, such as fuse capacity, fusing time and insertion circuit location, are required.
- [3] If your design includes an inductive load such as a motor coil, incorporate a protection circuit into the design to prevent device malfunction or breakdown caused by the current resulting from the inrush current at power ON or the negative current resulting from the back electromotive force at power OFF. IC breakdown may cause injury, smoke or ignition.
Use a stable power supply with ICs with built-in protection functions. If the power supply is unstable, the protection function may not operate, causing IC breakdown. IC breakdown may cause injury, smoke or ignition.
- [4] Do not insert devices in the wrong orientation or incorrectly.
Make sure that the positive and negative terminals of power supplies are connected properly.
Otherwise, the current or power consumption may exceed the absolute maximum rating, and exceeding the rating(s) may cause the device breakdown, damage or deterioration, and may result injury by explosion or combustion.
In addition, do not use any device that is applied the current with inserting in the wrong orientation or incorrectly even just one time.

Points to remember on handling of ICs**(1) Over current Protection Circuit**

Over current protection circuits (referred to as current limiter circuits) do not necessarily protect ICs under all circumstances. If the Over current protection circuits operate against the over current, clear the over current status immediately.

Depending on the method of use and usage conditions, such as exceeding absolute maximum ratings can cause the over current protection circuit to not operate properly or IC breakdown before operation. In addition, depending on the method of use and usage conditions, if over current continues to flow for a long time after operation, the IC may generate heat resulting in breakdown.

(2) Thermal Shutdown Circuit

Thermal shutdown circuits do not necessarily protect ICs under all circumstances. If the thermal shutdown circuits operate against the over temperature, clear the heat generation status immediately.

Depending on the method of use and usage conditions, such as exceeding absolute maximum ratings can cause the thermal shutdown circuit to not operate properly or IC breakdown before operation.

(3) Heat Radiation Design

In using an IC with large current flow such as power amp, regulator or driver, please design the device so that heat is appropriately radiated, not to exceed the specified junction temperature (T_j) at any time and condition. These ICs generate heat even during normal use. An inadequate IC heat radiation design can lead to decrease in IC life, deterioration of IC characteristics or IC breakdown. In addition, please design the device taking into consideration the effect of IC heat radiation with peripheral components.

(4) Back-EMF

When a motor rotates in the reverse direction, stops or slows down abruptly, a current flow back to the motor's power supply due to the effect of back-EMF. If the current sink capability of the power supply is small, the device's motor power supply and output pins might be exposed to conditions beyond maximum ratings. To avoid this problem, take the effect of back-EMF into consideration in system design.

Not Recommended
for New Design

RESTRICTIONS ON PRODUCT USE

- Toshiba Corporation, and its subsidiaries and affiliates (collectively "TOSHIBA"), reserve the right to make changes to the information in this document, and related hardware, software and systems (collectively "Product") without notice.
- This document and any information herein may not be reproduced without prior written permission from TOSHIBA. Even with TOSHIBA's written permission, reproduction is permissible only if reproduction is without alteration/omission.
- Though TOSHIBA works continually to improve Product's quality and reliability, Product can malfunction or fail. Customers are responsible for complying with safety standards and for providing adequate designs and safeguards for their hardware, software and systems which minimize risk and avoid situations in which a malfunction or failure of Product could cause loss of human life, bodily injury or damage to property, including data loss or corruption. Before customers use the Product, create designs including the Product, or incorporate the Product into their own applications, customers must also refer to and comply with (a) the latest versions of all relevant TOSHIBA information, including without limitation, this document, the specifications, the data sheets and application notes for Product and the precautions and conditions set forth in the "TOSHIBA Semiconductor Reliability Handbook" and (b) the instructions for the application with which the Product will be used with or for. Customers are solely responsible for all aspects of their own product design or applications, including but not limited to (a) determining the appropriateness of the use of this Product in such design or applications; (b) evaluating and determining the applicability of any information contained in this document, or in charts, diagrams, programs, algorithms, sample application circuits, or any other referenced documents; and (c) validating all operating parameters for such designs and applications. **TOSHIBA ASSUMES NO LIABILITY FOR CUSTOMERS' PRODUCT DESIGN OR APPLICATIONS.**
- Product is intended for use in general electronics applications (e.g., computers, personal equipment, office equipment, measuring equipment, industrial robots and home electronics appliances) or for specific applications as expressly stated in this document. Product is neither intended nor warranted for use in equipment or systems that require extraordinarily high levels of quality and/or reliability and/or a malfunction or failure of which may cause loss of human life, bodily injury, serious property damage or serious public impact ("Unintended Use"). Unintended Use includes, without limitation, equipment used in nuclear facilities, equipment used in the aerospace industry, medical equipment, equipment used for automobiles, trains, ships and other transportation, traffic signaling equipment, equipment used to control combustions or explosions, safety devices, elevators and escalators, devices related to electric power, and equipment used in finance-related fields. Do not use Product for Unintended Use unless specifically permitted in this document.
- Do not disassemble, analyze, reverse-engineer, alter, modify, translate or copy Product, whether in whole or in part.
- Product shall not be used for or incorporated into any products or systems whose manufacture, use, or sale is prohibited under any applicable laws or regulations.
- The information contained herein is presented only as guidance for Product use. No responsibility is assumed by TOSHIBA for any infringement of patents or any other intellectual property rights of third parties that may result from the use of Product. No license to any intellectual property right is granted by this document, whether express or implied, by estoppel or otherwise.
- **ABSENT A WRITTEN SIGNED AGREEMENT, EXCEPT AS PROVIDED IN THE RELEVANT TERMS AND CONDITIONS OF SALE FOR PRODUCT, AND TO THE MAXIMUM EXTENT ALLOWABLE BY LAW, TOSHIBA (1) ASSUMES NO LIABILITY WHATSOEVER, INCLUDING WITHOUT LIMITATION, INDIRECT, CONSEQUENTIAL, SPECIAL, OR INCIDENTAL DAMAGES OR LOSS, INCLUDING WITHOUT LIMITATION, LOSS OF PROFITS, LOSS OF OPPORTUNITIES, BUSINESS INTERRUPTION AND LOSS OF DATA, AND (2) DISCLAIMS ANY AND ALL EXPRESS OR IMPLIED WARRANTIES AND CONDITIONS RELATED TO SALE, USE OF PRODUCT, OR INFORMATION, INCLUDING WARRANTIES OR CONDITIONS OF MERCHANTABILITY, FITNESS FOR A PARTICULAR PURPOSE, ACCURACY OF INFORMATION, OR NONINFRINGEMENT.**
- Do not use or otherwise make available Product or related software or technology for any military purposes, including without limitation, for the design, development, use, stockpiling or manufacturing of nuclear, chemical, or biological weapons or missile technology products (mass destruction weapons). Product and related software and technology may be controlled under the Japanese Foreign Exchange and Foreign Trade Law and the U.S. Export Administration Regulations. Export and re-export of Product or related software or technology are strictly prohibited except in compliance with all applicable export laws and regulations.
- Please contact your TOSHIBA sales representative for details as to environmental matters such as the RoHS compatibility of Product. Please use Product in compliance with all applicable laws and regulations that regulate the inclusion or use of controlled substances, including without limitation, the EU RoHS Directive. TOSHIBA assumes no liability for damages or losses occurring as a result of noncompliance with applicable laws and regulations.

Mouser Electronics

Authorized Distributor

Click to View Pricing, Inventory, Delivery & Lifecycle Information:

Toshiba:

[TA8429HQ\(O\)](#) [TA8429HQ\(5\)](#)