

REV.	DESCRIPTION	DRAWN	CHECKED	APPROVED
A	NEW RELEASE	DMJ 07/18/07'		LJC 07/17/07'

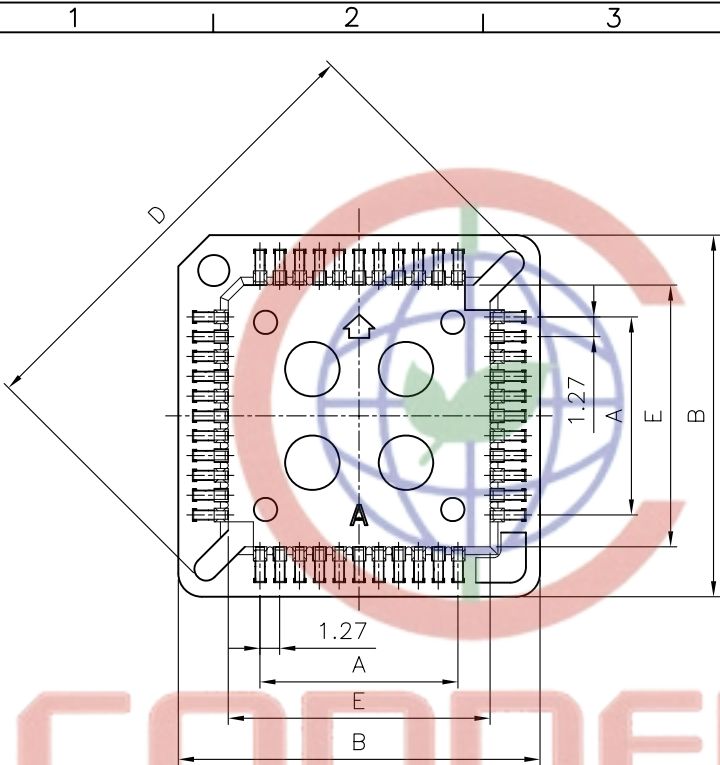

Dimension

Position	A±0.2	B±0.4	C±0.2	D±0.2	E±0.2
20	5.08	15.56	10.16	18.46	9.16
28	7.62	18.10	12.70	22.05	11.70
44	12.70	23.18	17.78	29.24	16.78
52	15.24	25.72	20.32	32.83	19.32
68	20.32	30.80	25.40	40.02	24.40
84	25.40	35.88	30.48	47.20	29.48

NOTES:

- MATERIAL
  - INSULATOR:THERMOPLASTIC(UL 94V-0).
  - CONTACT: COPPER ALLOY.
- SPECIFICATION
  - STORAGE TEMPERATURE:-20-70°C.
  - OPERATING TEMPERATURE:0-85°C.
  - CONTACT RESISTANCE:20mΩ max.
  - INSULATION RESISTANCE:1000MΩ min.
  - DIELECTRIC WITHSTANDING VOLTAGE:AC 500V PER MINUTE.
- PART NUMBER: DS1032
- PRODUCT NUMBER CODE:  
DS1032- X X X X X X

- PACKING  
A: TUBE
- CONTACT PLATING  
T1: Tin.
- HOUSING COLOR  
K: BLACK  
N: BROWN
- MOUNTING TYPE  
D: V/T DIP
- HOUSING MATERIAL  
S: PPS
- No.OF CONTACTS  
20 28 44  
52 68 84

CONNFLY

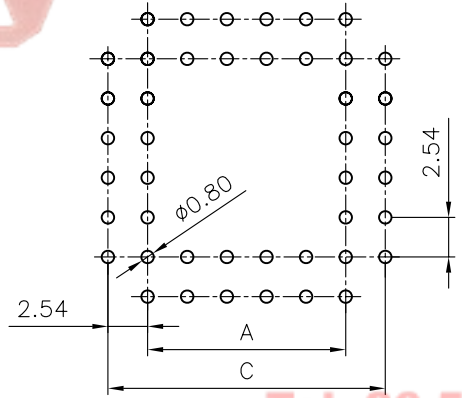
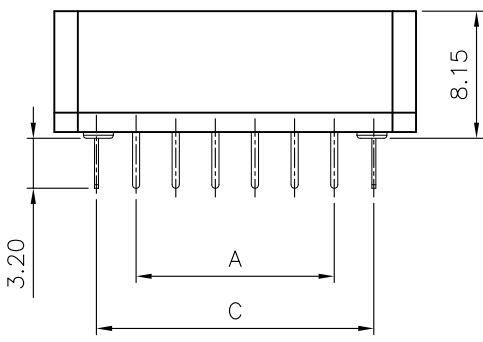

RECOMMEND PCB(V/T TYPE) LAYOUT  
TOLERANCE=±0.05

Tel: 86-574-63508787  
Fax: 86-574-63510817

GENERAL TOLERANCE	ANGLE TOLERANCE	PROJECTION	TITLE	PLCC 20/28/52/68/84pin DIP SOCKET
X. ±0.60	X. ±5°	UNITS mm		
.X ±0.38	.X ±3°	SHEET SIZE A4	SERIES DS1032 SERIES	
.XX ±0.25	.XX ±2°			
DRAWING TYPE	CUSTOMER	晨翔电子有限公司 CONNFLY CONNFLY ELECTRONIC CO. LTD		
SCALE	1:1 SHEET 1 OF 1			
DRAWING NO.	C-DS1032-XXXXXX			

REV.	DESCRIPTION	DRAWN	CHECKED	APPROVED
A	NEW RELEASE	DMJ 07/18/07'		LJC 07/17/07'

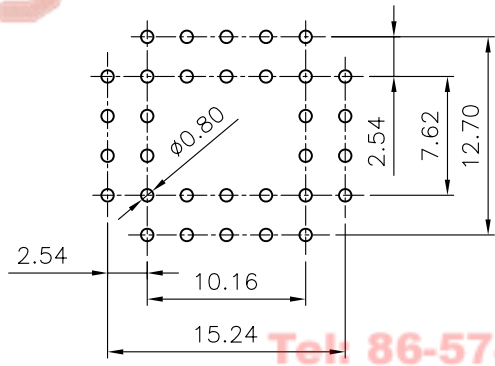
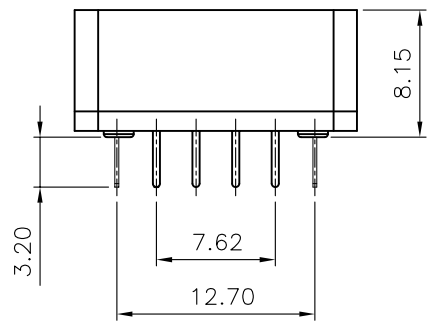
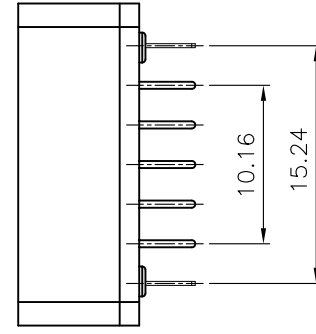
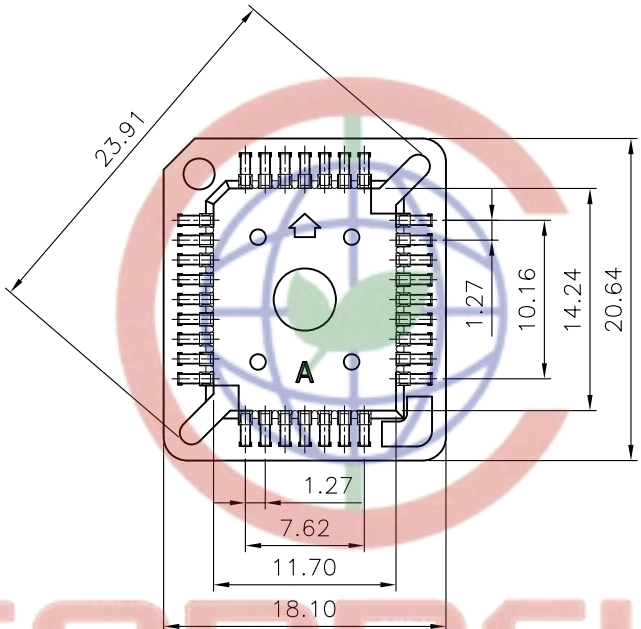

- NOTES:
- MATERIAL
    - INSULATOR:THERMOPLASTIC(UL 94V-0).
    - CONTACT: COPPER ALLOY.
  - SPECIFICATION
    - STORAGE TEMPERATURE:-20-70°C.
    - OPERATING TEMPERATURE:0-85°C.
    - CONTACT RESISTANCE:20mΩ max.
    - INSULATION RESISTANCE:1000MΩ min.
    - DIELECTRIC WITHSTANDING VOLTAGE:AC 500V PER MINUTE.
  - PART NUMBER: DS1032
  - PRODUCT NUMBER CODE:  
 DS1032- X X X X X X  
 X: PACKING  
 A: TUBE  
 T1: CONTACT PLATING  
 T1: Tin.  
 HOUSING COLOR  
 K: BLACK  
 N: BROWN  
 MOUNTING TYPE  
 D: V/T DIP  
 HOUSING MATERIAL  
 S: PPS  
 No.OF CONTACTS  
 32

RECOMMEND PCB(V/T TYPE) LAYOUT  
 TOLERANCE=±0.05

GENERAL TOLERANCE	ANGLE TOLERANCE	PROJECTION	TITLE
X. ±0.60	X. ±5°		PLCC 32pin DIP SOCKET
.X ±0.38	.X ±3°	UNITS mm	SHEET SIZE A4
.XX ±0.25	.XX ±2°	SHEET SIZE A4	SERIES DS1032 SERIES
DRAWING TYPE	CUSTOMER	晨翔电子有限公司 <b>CONNFLY CONNFLY ELECTRONIC CO. LTD</b>	
SCALE	1:1	SHEET	1 OF 1
DRAWING NO.	C-DS1032-32XXXXX		

FOR 32pin ONLY

Tel: 86-574-63508787  
 Fax: 86-574-63510817

Http://www.connfly.com.cn  
 Add.: West Gaozhou City Ningbo China  
 315321

REV.	DESCRIPTION	DRAWN	CHECKED	APPROVED
A	NEW RELEASE	YCH 11/13/07'		

NOTES:

- MATERIAL
  - INSULATOR: THERMOPLASTIC,PPS CLASS FIRBER FILLED(UL 94V-0).
  - CONTACT: PHOSPHOR BRONZE.
- SPECIFICATION
  - STORAGE TEMPERATURE:-20-70°C.
  - OPERATING TEMPERATURE:0-85°C.
  - CONTACT RESISTANCE:20mΩ max.
  - INSULATION RESISTANCE:1000MΩ min.
  - DIELECTRIC WITHSTANDING VOLTAGE:AC 500V PER MINUTE.

- PART NUMBER: DS1032 SMT TYPE
- PRODUCT NUMBER CODE:

DS1032- X X X X X X X

- X: PACKING
- A: TUBE
- R: TAPE ON REEL
- L: PROFILE HEIGHT(DIM H) 4.6mm
- T1: CONTACT PLATING Tin.
- K: HOUSING COLOR BLACK
- N: HOUSING COLOR BROWN
- S: MOUNTING TYPE SMT
- S: HOUSING MATERIAL PPS
- No.OF CONTACTS: 20 28 32 44 52 68 84

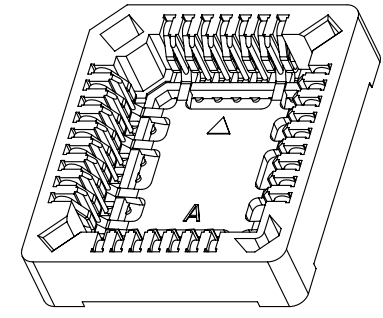
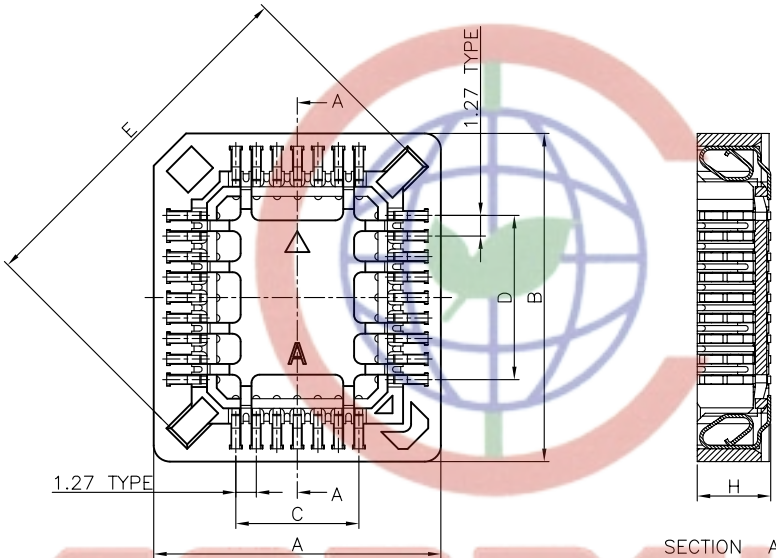

Dimension

Position	A±0.2	B±0.4	C±0.2	D±0.2	E±0.2
20	15.24	15.24	5.08	5.08	16.70
28	17.78	17.78	7.62	7.62	20.30
32	17.78	20.32	7.62	10.16	22.50
44	22.86	22.86	12.70	12.70	27.50
52	25.40	25.40	15.24	15.24	31.10
68	30.82	30.82	20.32	20.32	38.30
84	35.90	35.90	25.40	25.40	45.50

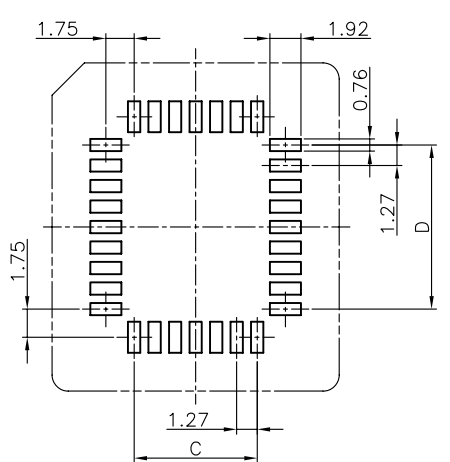

RECOMMEND PCB LAYOUT TOLERANCE=±0.05

Tel: 86-574-63508787  
Fax: 86-574-63510817

GENERAL TOLERANCE	ANGLE TOLERANCE	PROJECTION	TITLE
X. ±0.60	X. ±5°	UNITS mm	PLCC SOCKET SMT TYPE
.X ±0.38	.X ±3°	SHEET SIZE A4	SERIES DS1032 SERIES
.XX ±0.25	.XX ±2°		
DRAWING TYPE	CUSTOMER		
SCALE	1:1 SHEET 1 OF 1		
DRAWING NO.	C-DS1032-XSSXXX-A		

晨翔电子有限公司  
CONNFLY CONNFLY ELECTRONIC CO. LTD