

S15WB60

600V 15A

OUTLINE DIMENSIONS

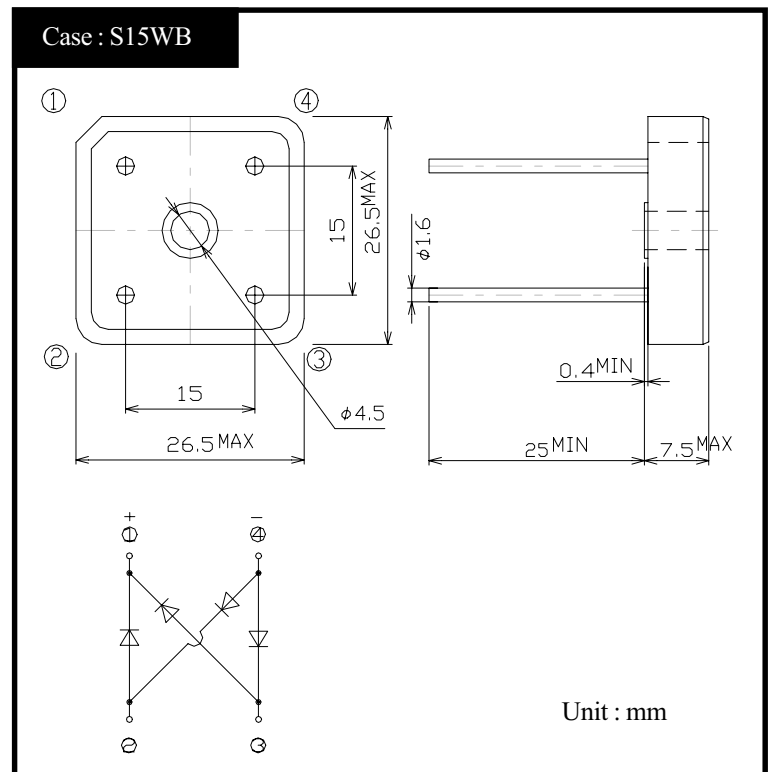

RATINGS

● Absolute Maximum Ratings

Item	Symbol	Conditions	Ratings	Unit
Storage Temperature	T_{stg}		-40~150	°C
Operating Junction Temperature	T_j		150	°C
Maximum Reverse Voltage	V_{RM}		600	V
Average Rectified Forward Current	I_O	50Hz sine wave, R-load With heatsink $T_c=77^\circ\text{C}$	15	A
		50Hz sine wave, R-load Without heatsink $T_a=25^\circ\text{C}$	4	
Peak Surge Forward Current	I_{FSM}	50Hz sine wave, Non-repetitive 1cycle peak value, $T_j=25^\circ\text{C}$	200	A
Current Squared Time	I^2t	$1\text{ms} \leq t < 10\text{ms}$ $T_j=25^\circ\text{C}$	200	A^2s
Dielectric Strength	V_{dis}	Terminals to case, AC 1 minute	2	kV
Mounting Torque	TOR	(Recommended torque : 1N·m)	2	N·m

● Electrical Characteristics (If not specified $T_c=25^\circ\text{C}$)

Item	Symbol	Conditions	Ratings	Unit
Forward Voltage	V_F	$I_F=7.5\text{A}$, Pulse measurement, Rating of per diode	Max.1.05	V
Reverse Current	I_R	$V_R=V_{RM}$, Pulse measurement, Rating of per diode	Max.10	μA
Thermal Resistance	θ_{jc}	junction to case	Max.2.5	°C/W
	θ_{jl}	junction to lead	Max.2	
	θ_{ja}	junction to ambient	Max.19	

S15WBx

Forward Voltage

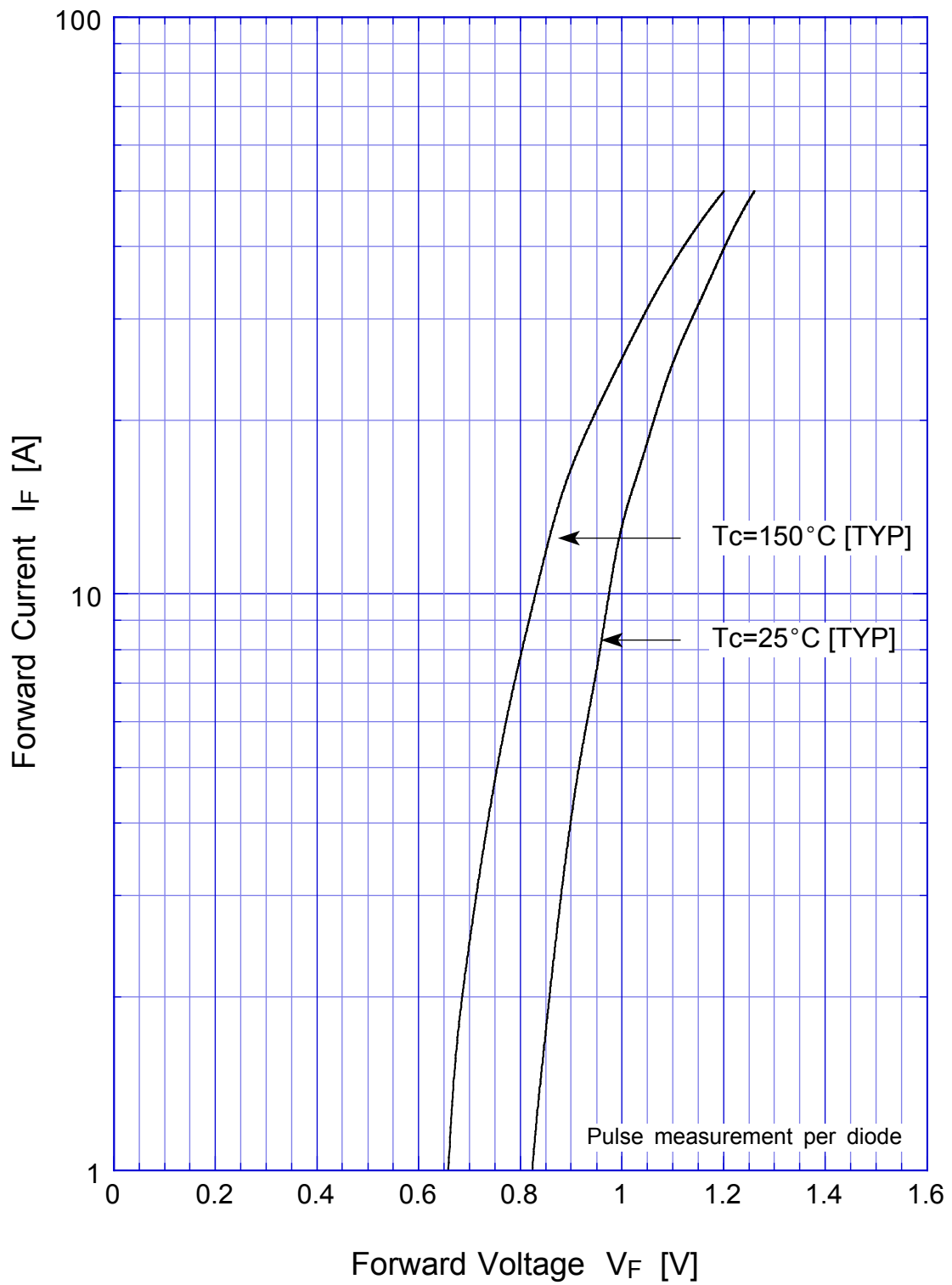

S15WBx Forward Power Dissipation

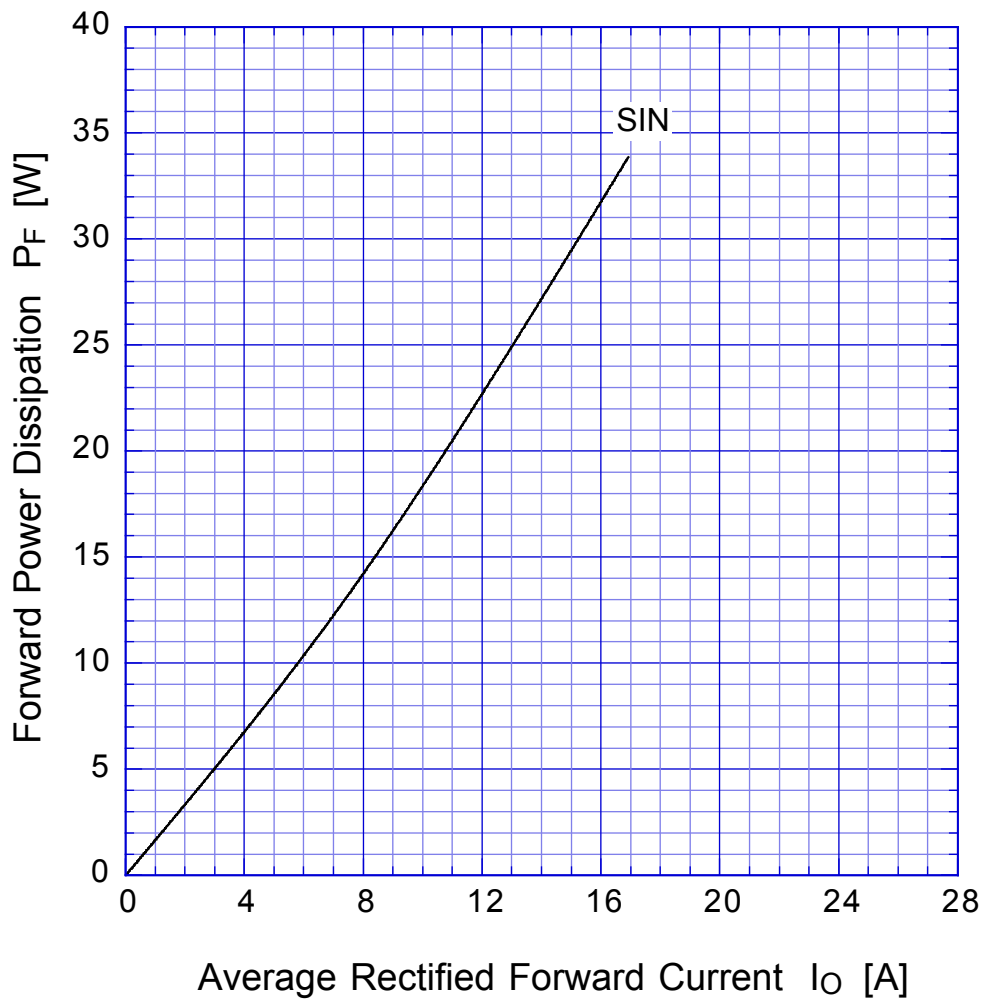

$T_j = 150^\circ\text{C}$
Sine wave

S15WBx

Derating Curve

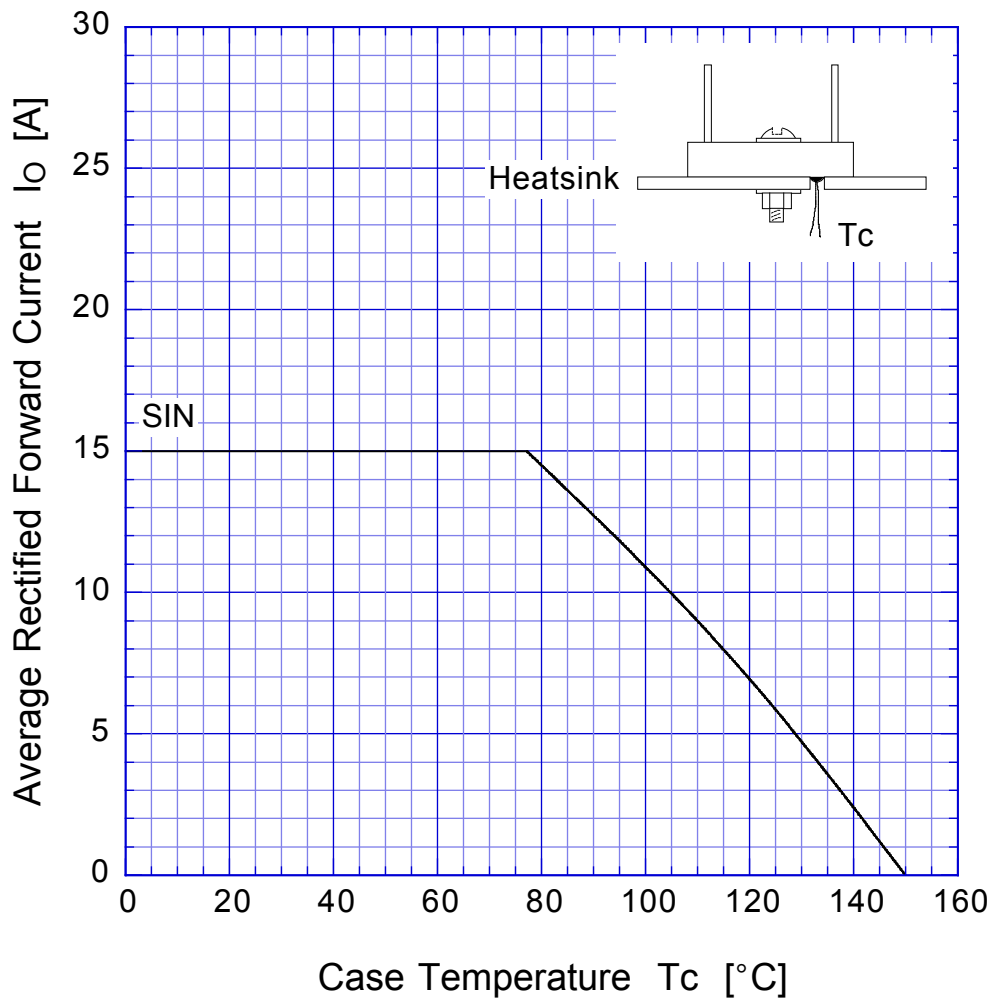

Sine wave
R-load
with heatsink

S15WBx

Derating Curve

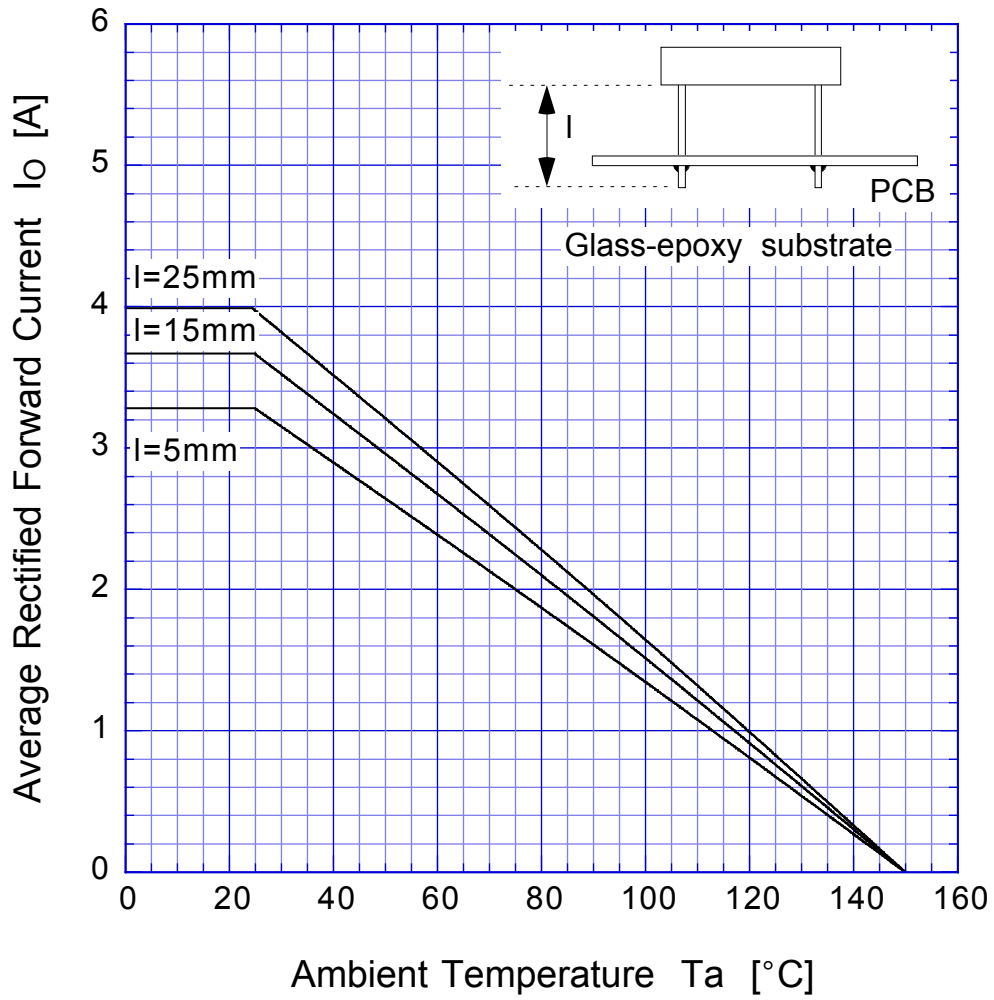

Sine wave
R-load
Free in air

S15WBx

Peak Surge Forward Capability

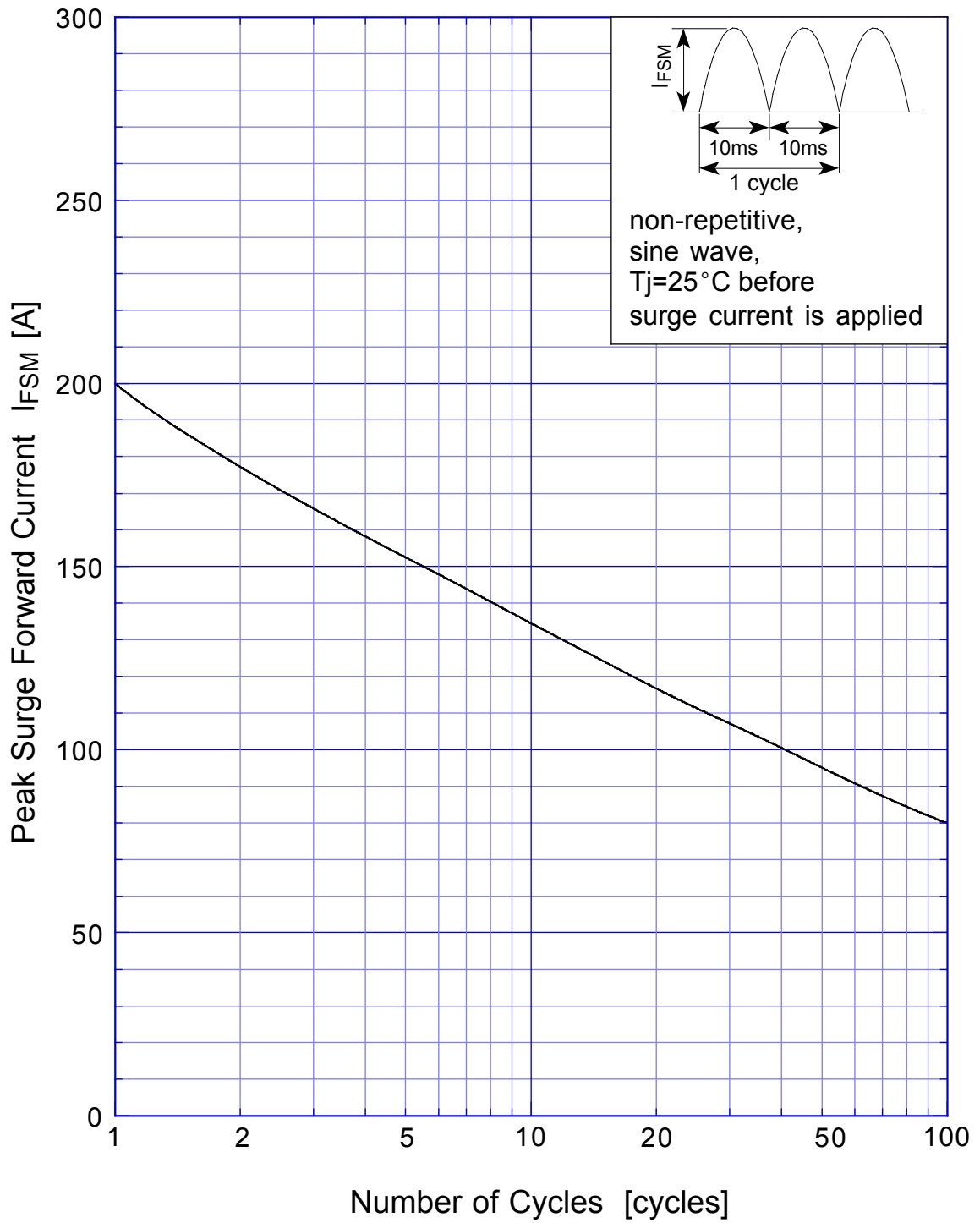

This datasheet has been download from:

www.datasheetcatalog.com

Datasheets for electronics components.