

Distributed by:

JAMECO[®]
ELECTRONICS

www.Jameco.com ♦ 1-800-831-4242

The content and copyrights of the attached
material are the property of its owner.

Jameco Part Number 1470274

THREE PHASE MOTOR DRIVER

- SUPPLY VOLTAGE FROM 7 TO 52V
- 5A PEAK CURRENT
- $R_{DS\ ON}$ 0.3Ω TYP. VALUE AT 25°C
- CROSS CONDUCTION PROTECTION
- TTL COMPATIBLE DRIVER
- OPERATING FREQUENCY TO 50KHz
- THERMAL SHUTDOWN
- INTRINSIC FAST FREE WHEELING DIODES
- INPUT AND ENABLE FUNCTION FOR EVERY HALF BRIDGE
- 10V EXTERNAL REFERENCE AVAILABLE

DESCRIPTION

The L6234 is a triple half bridge to drive a brushless motor.

It is realized in Multipower BCD technology which combines isolated DMOS power transistors with CMOS and Bipolar circuits on the same chip.

By using mixed technology it has been possible to optimize the logic circuitry and the power stage to achieve the best possible performance.

The output DMOS transistors can sustain a very high current due to the fact that the DMOS structure is not affected by the second breakdown ef-

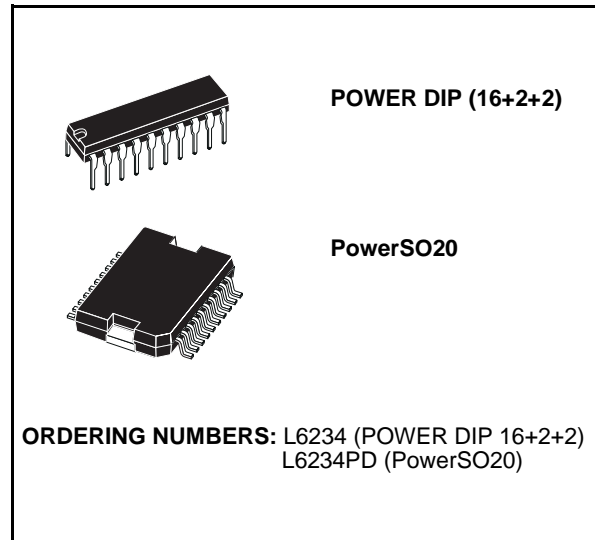

fect, the RMS maximum current is practically limited by the dissipation capability of the package. All the logic inputs are TTL, CMOS and μP compatible. Each channel is controlled by two separate logic input.

L6234 is available in 20 pin POWER DIP package (16+2+2) and in PowerSO20.

PIN CONNECTION (Top view)

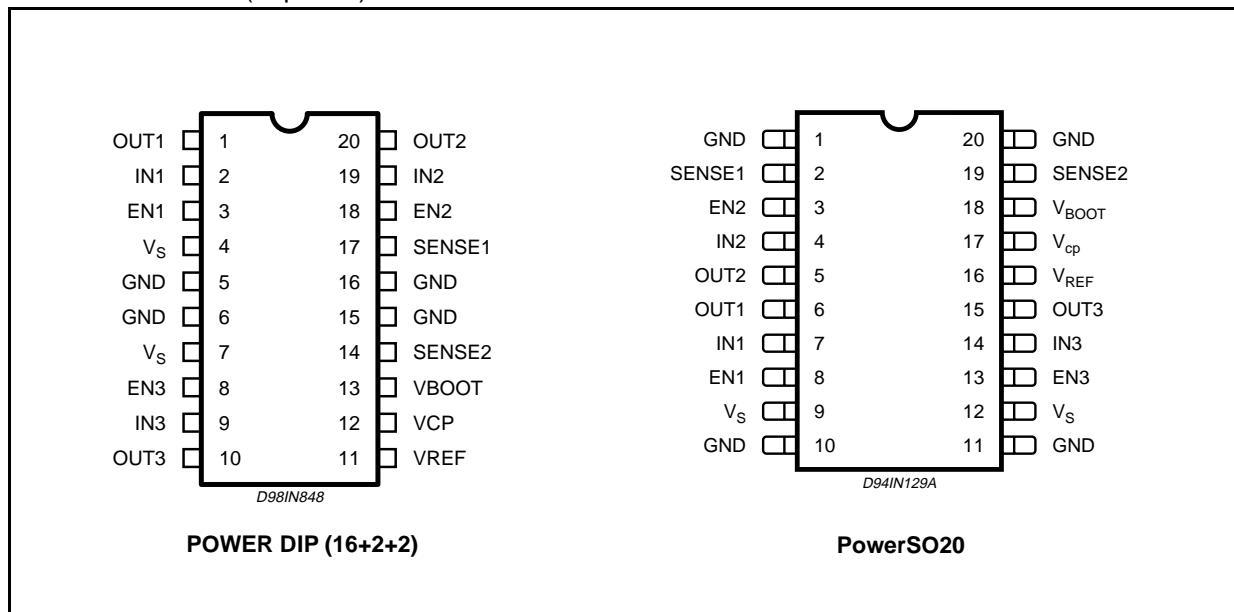

BLOCK DIAGRAM

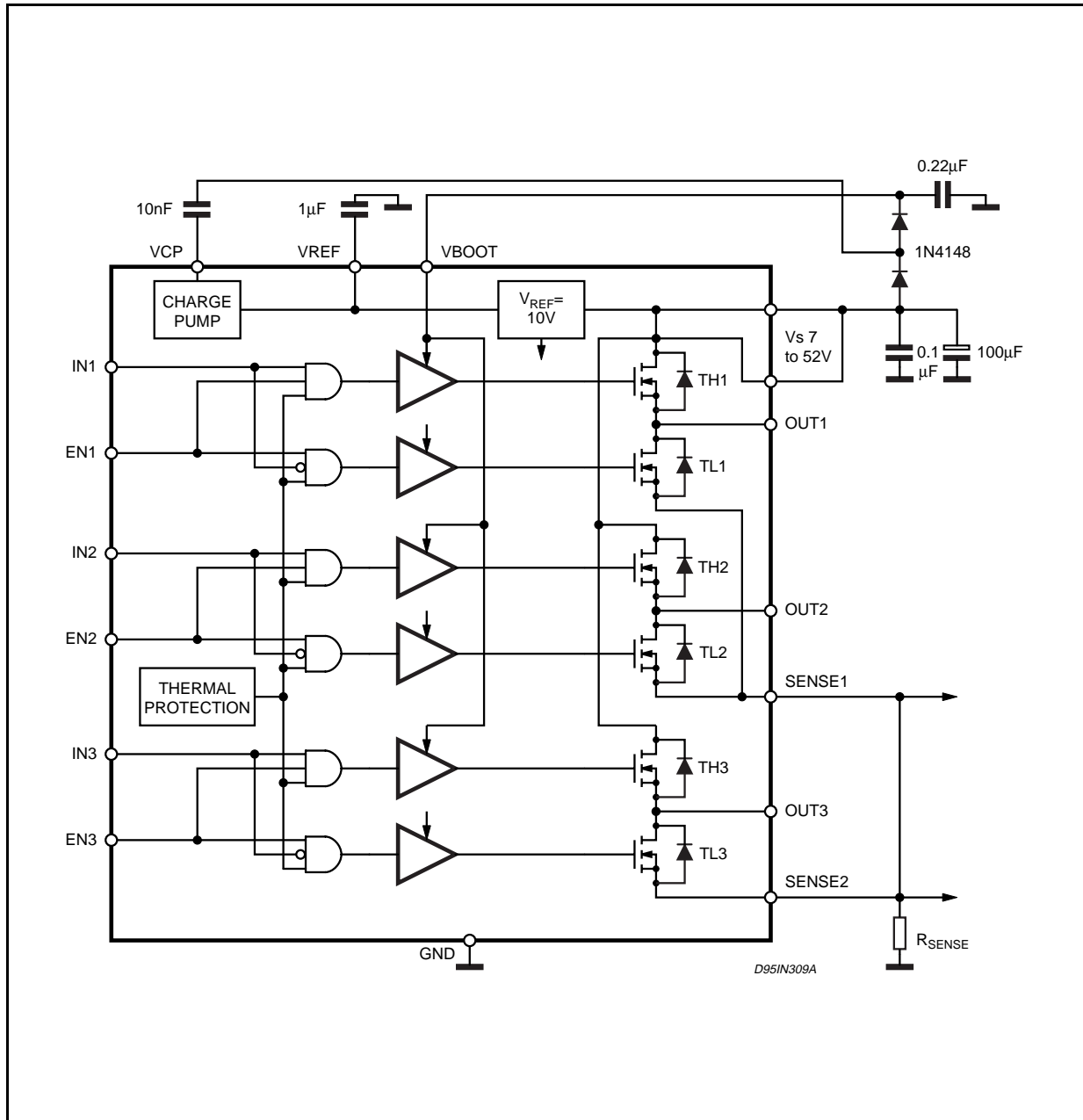

THERMAL DATA

Symbol	Parameter	DIP16+2+2	PowerSO20	Unit
$R_{th\ j-pin}$	Thermal Resistance, Junction to Pin	12	–	°C/W
$R_{th\ j-amb1}$	Thermal Resistance, Junction to Ambient (see Thermal Characteristics)	40	–	°C/W
$R_{th\ j-amb2}$	Thermal Resistance, Junction to Ambient (see Thermal Characteristics)	50	–	°C/W
$R_{th\ j-case}$	Thermal Resistance Junction-case	–	1.5	°C/W

THERMAL CHARACTERISTICS

$R_{th\ j-pins}$

DIP16+2+2. The thermal resistance is referred to the thermal path from the dissipating region on the top surface of the silicon chip, to the points along the four central pins of the package, at a distance of 1.5 mm away from the stand-offs.

$R_{th\ j-amb1}$

If a dissipating surface, thick at least 35 μm , and with a surface similar or bigger than the one shown, is created making use of the printed circuit.

Such heatsinking surface is considered on the bottom side of an horizontal PCB (worst case).

$R_{th\ j-amb2}$

If the power dissipating pins (the four central

ones), as well as the others, have a minimum thermal connection with the external world (very thin strips only) so that the dissipation takes place through still air and through the PCB itself.

It is the same situation of point above, without any heatsinking surface created on purpose on the board.

Additional data on the PowerDip and the PowerSO20 package can be found in:

Application Note AN467:
Thermal Characteristics of the PowerDip
20,24 Packages Soldered on 1,2,3 oz.
Copper PCB

Application Note AN668:
A New High Power IC Surface Mount Package:
PowerSO20 Power IC Packaging from Insertion
to Surface Mounting.

Figure 1: Printed Heatsink

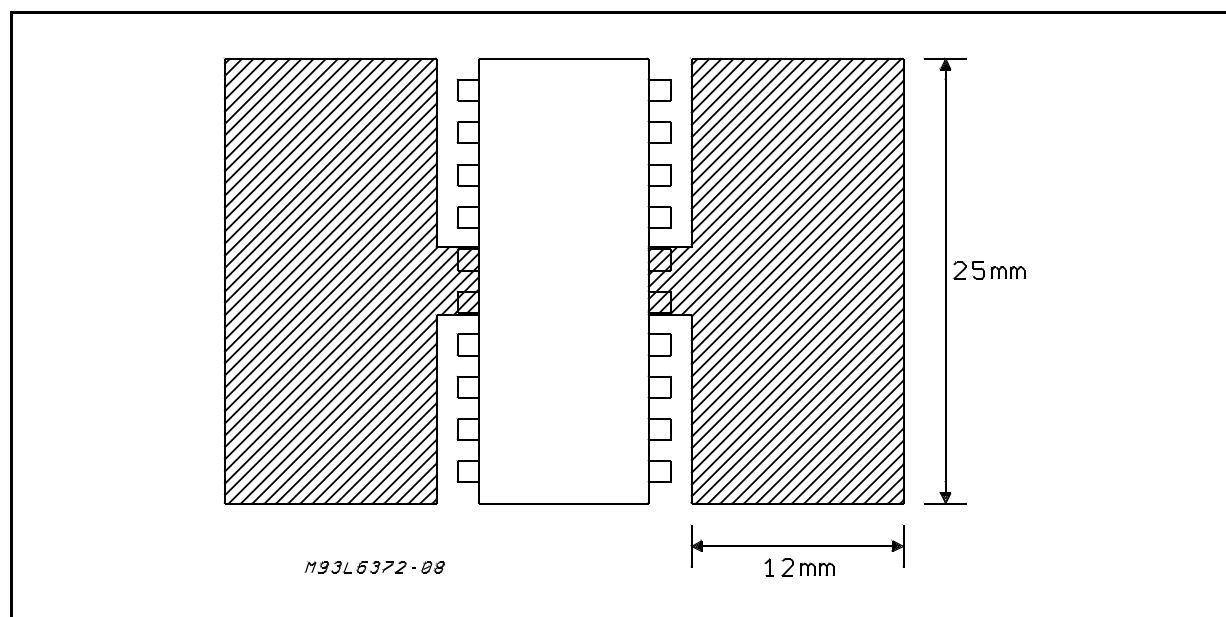

ABSOLUTE MAXIMUM RATINGS

Symbol	Parameter	Value	Unit
V _S	Power Supply Voltage	52	V
V _{IN} , V _{EN}	Input Enable Voltage	- 0.3 to 7	V
I _{peak}	Pulsed Output Current (note 1)	5	A
V _{SENSE}	Sensing Voltage (DC Voltage)	-1 to 4	V
V _b	Bootstrap Peak Voltage	62	V
V _{OD}	Differential Output Voltage (between any of the 3 OUT pins)	60	V
f _C	Commutation Frequency	50	KHz
V _{REF}	Reference Voltage	12	V
P _{tot}	Total Power Dissipation L6234PD T _{amb} = 70°C	2.3	W
P _{tot}	Total Power Dissipation L6234 T _{amb} = 70°C	1.6 (*)	W
T _{stg} , T _j	Storage and Junction Temperature Range	-40 to 150	°C

Note 1: Pulse width limited only by junction temperature and the transient thermal impedance
 (*) Mounted on board with minimized copper area

RECOMMENDED OPERATING CONDITIONS

Symbol	Parameter	Value	Unit
V _S	Supply Voltage	7 to 42	V
V _{OD}	Peak to Peak Differential Voltage (between any of the 3 OUT pins)	52	V
I _{out}	DC Output Current Power SO20 (T _{amb} = 25°C)	4	A
	DC Output Current Power DIP (T _{amb} = 25°C) with infinite heatsink	2.8	A
V _{SENSE}	Sensing Voltage (pulsed t _w < 300nsec)	-4 to 4	V
	Sensing Voltage (DC)	-1 to 1	V
T _j	Junction Temperature Range	-40 to 125	°C

PIN FUNCTIONS

Powerdip	PowerSO20	Name	Function
1 20 10	6 5 15	OUT 1 OUT 2 OUT 3	Output of the channels 1/2/3.
2 19 9	7 4 14	IN 1 IN 2 IN 3	Logic input of channels 1/2/3. A logic HIGH level (when the corresponding EN pin is HIGH) switches ON the upper DMOS Power Transistor, while a logic LOW switches ON the corresponding low side DMOS Power.
3 18 8	8 3 13	EN 1 EN 2 EN 3	Enable of the channels 1/2/3. A logic LOW level on this pin switches off both power DMOS of the related channel.
4,7	9, 12	V _s	Power Supply Voltage.
14	19	SENSE2	A resistance R _{sense} connected to this pin provides feedback for motor current control for the bridge 3.
17	2	SENSE1	A resistance R _{sense} connected to this pin provides feedback for motor current control for the bridges 1 and 2.
11	16	V _{ref}	Internal Voltage Reference. A capacitor connected from this pin to GND increases the stability of the Power DMOS drive circuit.
12	17	V _{cp}	Bootstrap Oscillator. Oscillator output for the external charge pump.
13	18	V _{BOOT}	Overvoltage input to drive the upper DMOS
5,6 15,16	1,10 11,20	GND	Common Ground Terminal. In Powerdip and SO packages these pins are used to dissipate the heat forward the PCB.

ELECTRICAL CHARACTERISTICS ($V_s = 42V$; $T_j = 25^\circ C$ unless otherwise specified)

Symbol	Parameter	Test Condition	Min.	Typ.	Max.	Unit
V_s	Supply Voltage		7		52	V
V_{ref}	Reference Voltage			10		V
I_s	Quiescent Supply Current			6.5		mA
T_s	Thermal Shutdown		150			$^\circ C$
T_D	Dead Time Protection			300		ns

OUTPUT DMOS TRANSISTOR

Symbol	Parameter	Test Condition	Min.	Typ.	Max.	Unit
I_{DSS}	Leakage Current				1	mA
$R_{DS(ON)}$	ON Resistance			0.3		Ω

SOURCE DRAIN DIODE

Symbol	Parameter	Test Condition	Min.	Typ.	Max.	Unit
V_{SD}	Forward ON Voltage	$I_{SD} = 4A$; EN = LOW		1.2		V
T_{RR}	Reverse Recovery Time	$I_F = 4A$		900		ns
T_{pr}	Forward Recovery Time			200		ns

LOGIC LEVELS

Symbol	Parameter	Test Condition	Min.	Typ.	Max.	Unit
V_{INL}, V_{ENL}	Input LOW Voltage		-0.3		0.8	V
V_{INH}, V_{ENH}	Input HIGH Voltage		2		7	V
I_{INL}, I_{ENL}	Input LOW Current	$V_{IN}, V_{EN} = L$			-10	μA
I_{INH}, I_{ENH}	Input HIGH Current	$V_{IN}, V_{EN} = H$		30		μA

CIRCUIT DESCRIPTION

L6234 is a triple half bridge designed to drive brushless DC motors.

Each half bridge has 2 power DMOS transistors with $R_{dsON} = 0.3\Omega$. The 3 half bridges can be controlled independently by means of the 3 inputs IN1, IN2, IN3 and the 3 inputs EN1, EN2, and

EN3. An external connection to the 3 common low side DMOS sources is provided to connect a sensing resistor for constant current chopping application.

The driving stage and the logic stage are designed to work from 7V to 52V.

Figure 1. Quiescent Current vs. Supply Voltage.

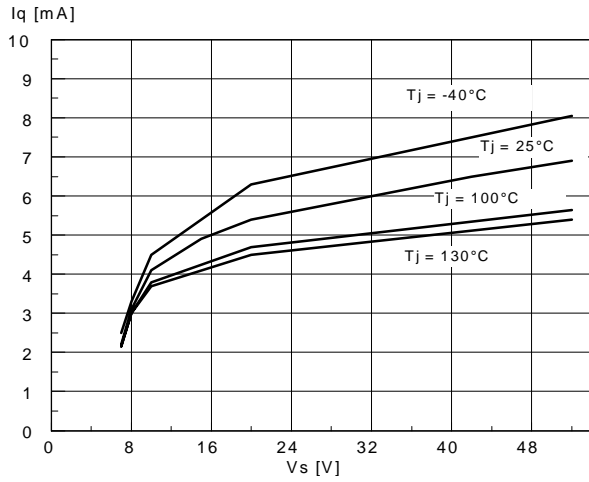

Figure 2. Normalized Quiescent Current vs. switching frequency.

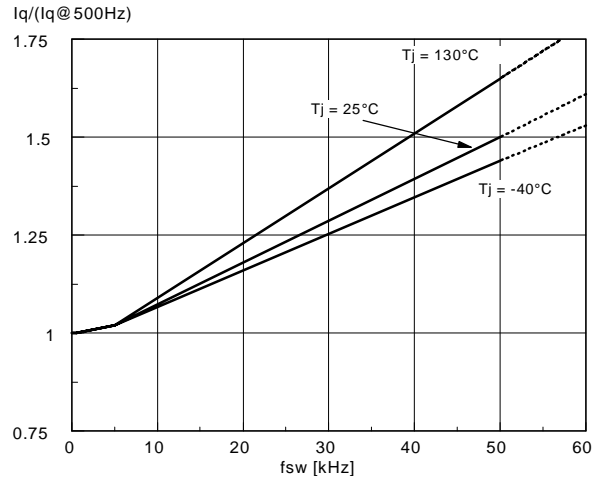

Figure 3. Typical RDS (ON) vs. Supply Voltage.

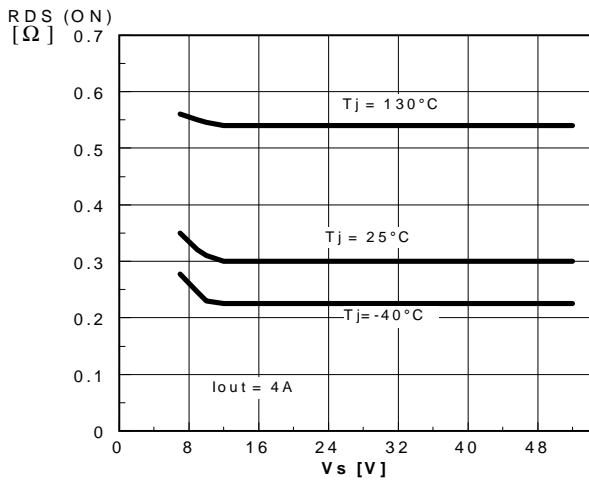

Figure 4. Source Drain Forward ON voltage vs. Junction Temperature.

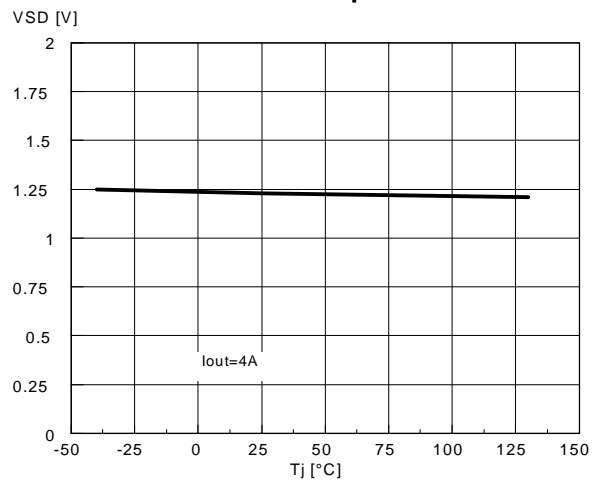

Figure 5. Typical Diode Forward ON characteristics

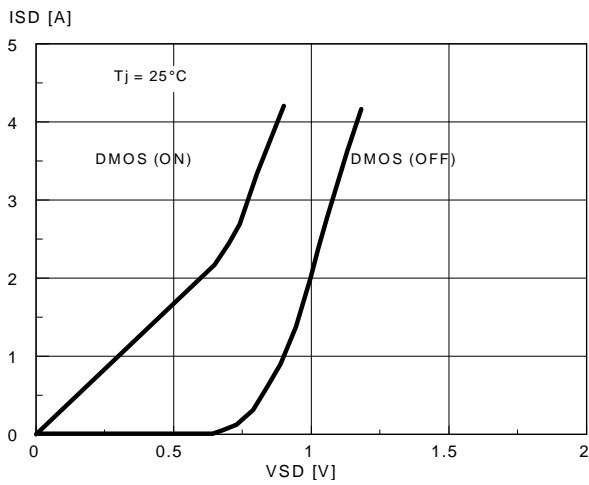

Figure 6. Reference Voltage vs. Supply Voltage.

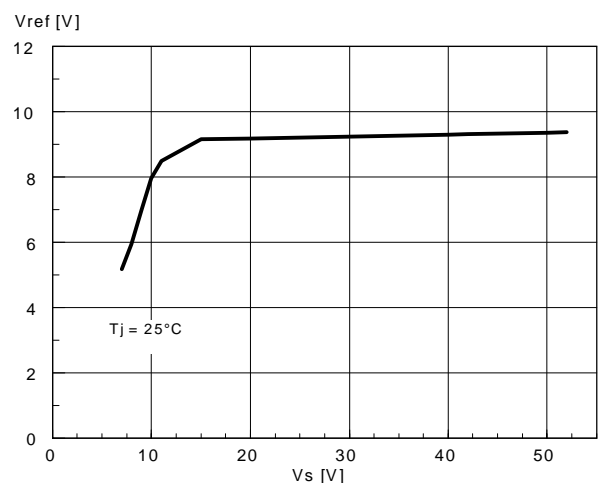

Figure 7. Reference Voltage vs. Junction Temperature.

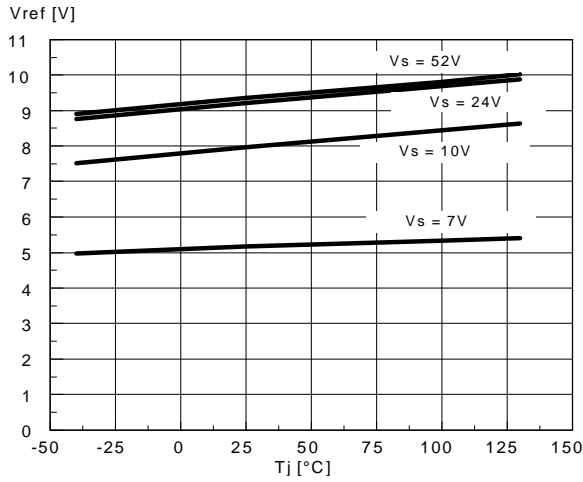

Figure 8. PowerSO-20 Transient Thermal Resistance

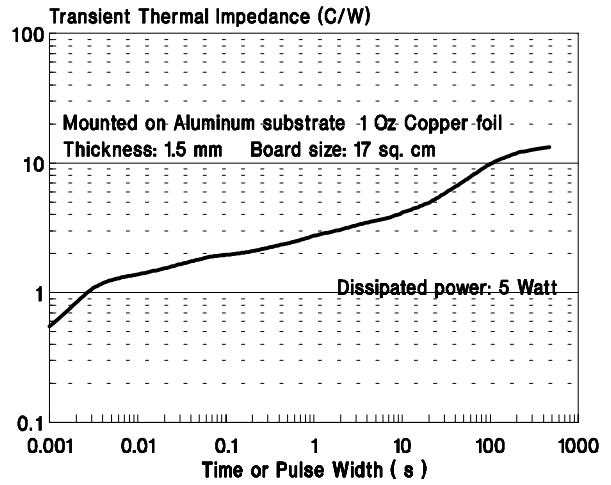

Figure 9. PowerSO-20 Thermal Resistance (Mounted on Aluminium substrate)

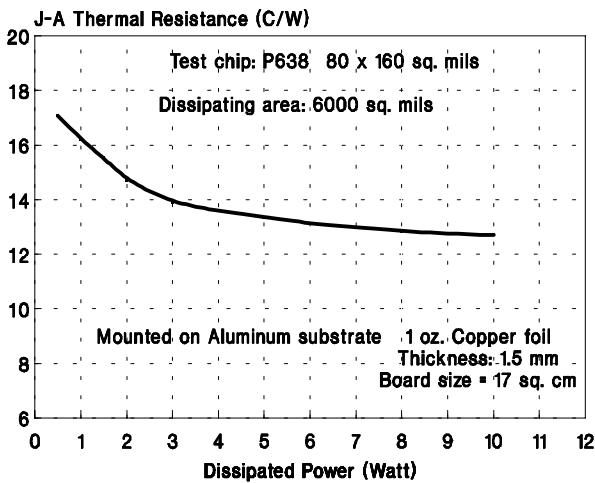

Figure 10. PowerSO-20 Thermal Resistance (Mounted on FR4 monolayer substrate)

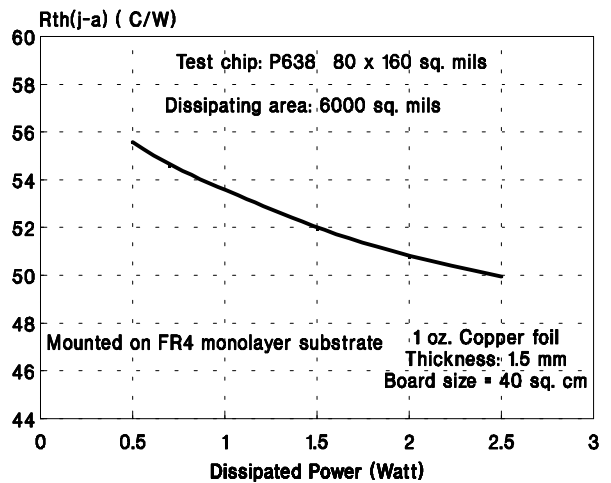

Figure 11. PowerSO-20: with external heatsink

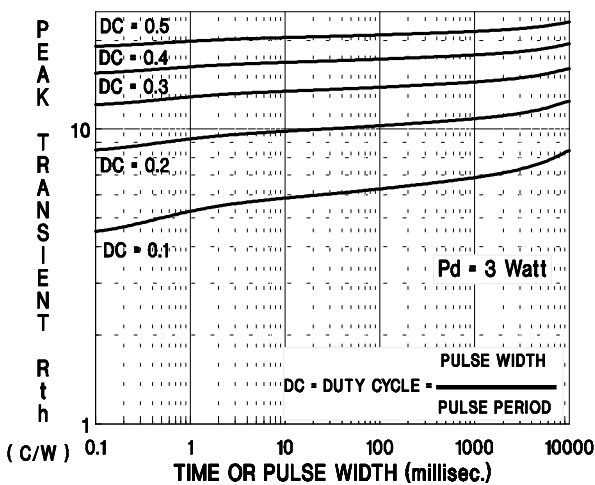
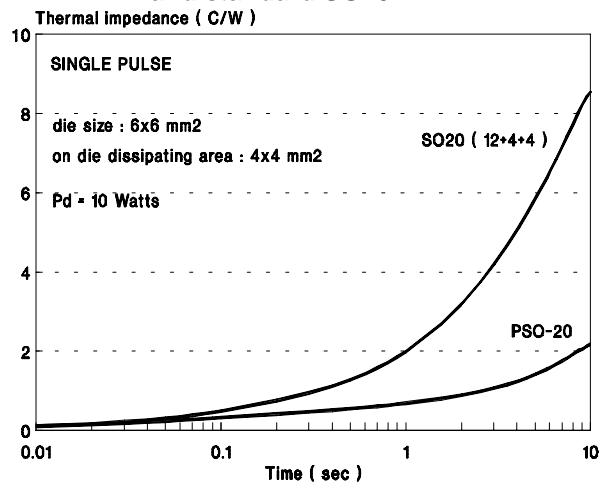

Figure 12. Thermal Impedance of PowerSO-20 and standard SO20



DIM.	mm			inch		
	MIN.	TYP.	MAX.	MIN.	TYP.	MAX.
A			3.6			0.142
a1	0.1		0.3	0.004		0.012
a2			3.3			0.130
a3	0		0.1	0.000		0.004
b	0.4		0.53	0.016		0.021
c	0.23		0.32	0.009		0.013
D (1)	15.8		16	0.622		0.630
D1	9.4		9.8	0.370		0.386
E	13.9		14.5	0.547		0.570
e		1.27			0.050	
e3		11.43			0.450	
E1 (1)	10.9		11.1	0.429		0.437
E2			2.9			0.114
E3	5.8		6.2	0.228		0.244
G	0		0.1	0.000		0.004
H	15.5		15.9	0.610		0.626
h			1.1			0.043
L	0.8		1.1	0.031		0.043
N	8° (typ.)					
S	8° (max.)					
T		10			0.394	

(1) "D and E1" do not include mold flash or protusions.
 - Mold flash or protusions shall not exceed 0.15mm (0.006")
 - Critical dimensions: "E", "G" and "a3".

OUTLINE AND MECHANICAL DATA

Weight: 1.9gr

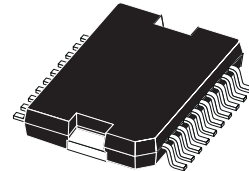

JEDEC MO-166

PowerSO20

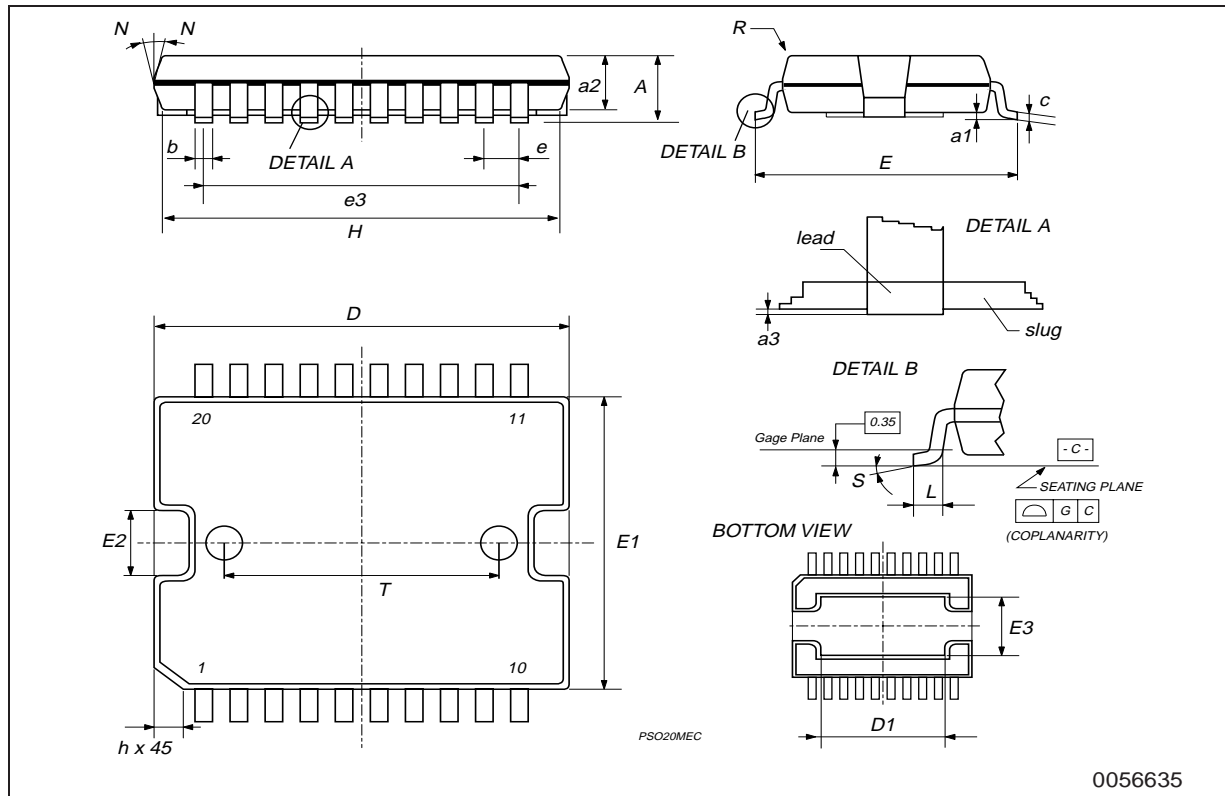

DIM.	mm			inch		
	MIN.	TYP.	MAX.	MIN.	TYP.	MAX.
a1	0.51			0.020		
B	0.85		1.40	0.033		0.055
b		0.50			0.020	
b1	0.38		0.50	0.015		0.020
D			24.80			0.976
E		8.80			0.346	
e		2.54			0.100	
e3		22.86			0.900	
F			7.10			0.280
I			5.10			0.201
L		3.30			0.130	
Z			1.27			0.050

OUTLINE AND MECHANICAL DATA

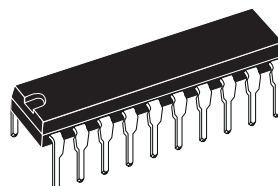

Powerdip 20

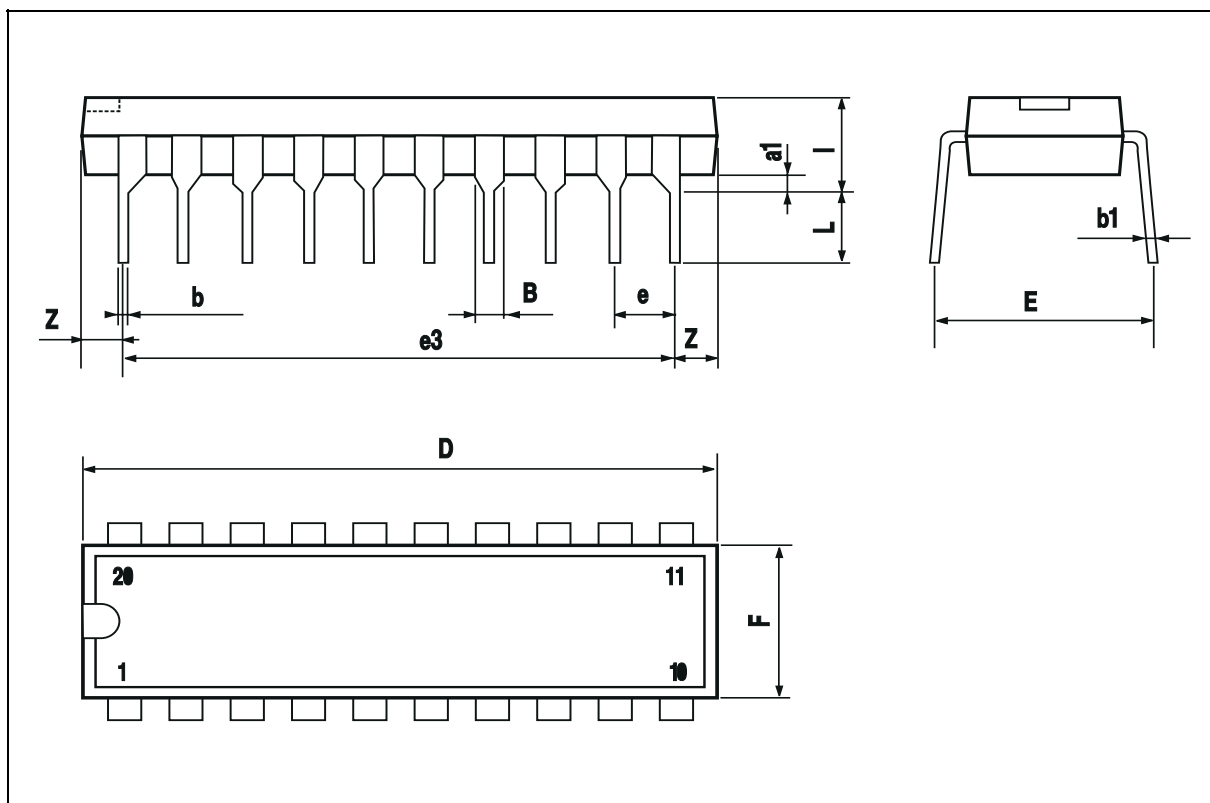

Information furnished is believed to be accurate and reliable. However, STMicroelectronics assumes no responsibility for the consequences of use of such information nor for any infringement of patents or other rights of third parties which may result from its use. No license is granted by implication or otherwise under any patent or patent rights of STMicroelectronics. Specification mentioned in this publication are subject to change without notice. This publication supersedes and replaces all information previously supplied. STMicroelectronics products are not authorized for use as critical components in life support devices or systems without express written approval of STMicroelectronics.

The ST logo is a registered trademark of STMicroelectronics

© 2003 STMicroelectronics – Printed in Italy – All Rights Reserved

STMicroelectronics GROUP OF COMPANIES

Australia - Brazil - Canada - China - Finland - France - Germany - Hong Kong - India - Israel - Italy - Japan - Malaysia - Malta - Morocco - Singapore - Spain - Sweden - Switzerland - United Kingdom - United States.

<http://www.st.com>