

# 0.9V Boost Driver PR4403 for White LEDs in Solar Lamps

The PR4403 is a single cell step-up converter for white LEDs operating from a single rechargeable cell of 1.2V supply voltage down to less than 0.9V. An adjustable light threshold input enables an automatic switching of the LED light, e. g. by an additional light sensor or by the battery charging solar cell itself. Only three external components are required for operation of a white LED. The PR4403 is recommended for mean LED currents of up to 40mA. This makes PR4403 ideal for use in low-cost or small-sized light applications such as solar LED lamps, LED flashlights or LCD backlighting for portable devices.

## Features

- only one 1.2V battery cell needed
- 250mA peak output current
- low number of external components
- battery deep discharge protection
- adjustable light threshold for switching on

## Applications

- Solar garden lamps
- House number lighting
- LED indicator lights with solar cells
- Solar powered LED torches
- model making, solar powered toys

## Typical Applications

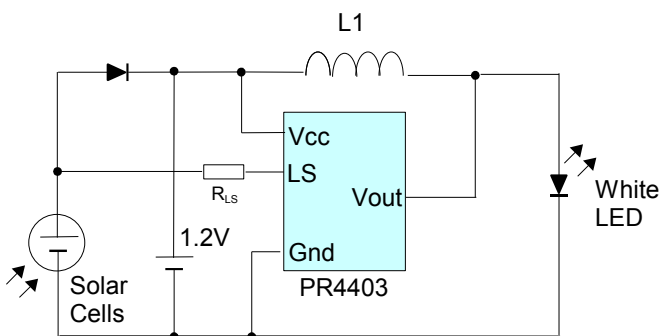

The inductance L1 determines the LED current:

Inductance L1	Mean current
14.7 $\mu$ H	14 mA
10 $\mu$ H	22 mA
6.8 $\mu$ H	32 mA
4.7 $\mu$ H	40 mA

measured with inductor Murata type LQH32CN series  
10-22 $\mu$ H: one white LED  
4.7-6.8 $\mu$ H: two white LEDs in parallel  
For output currents higher than 20mA an additional blocking capacitor at Vcc is recommended.

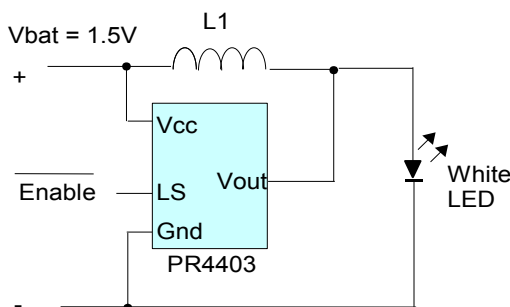

The circuit is operating in case that the pin LS is not connected or connected to Gnd. The circuit is shut down when the voltage at LS is higher than Voff.

## Pin Description PR4403

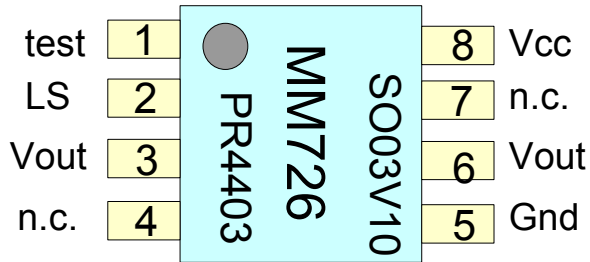

Pin No	Pin Name	Pin Function Description
1	test	test pin - do not connect
2	LS	LS - Enable Pin
3	Vout	Output voltage, LED connection <b>Connect both pin 3 and 6!</b>
4	n.c.	Not connected
5	Gnd	Ground connection
6	Vout	Output voltage, LED connection <b>Connect both pin 3 and 6!</b>
7	n.c.	not connected
8	Vcc	Supply voltage

Package SO8 or COB on request

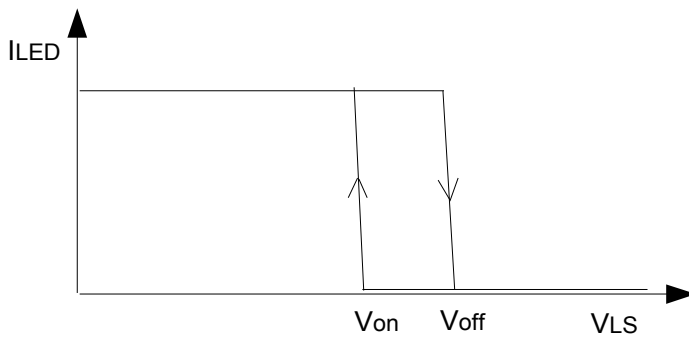

Switching behaviour of PR4403

## Block Diagram

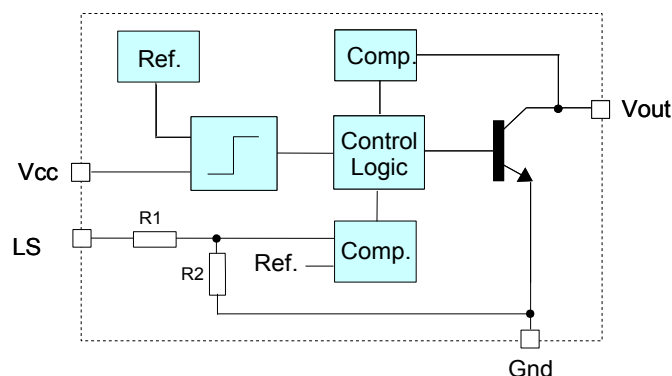

### Absolute Maximum Ratings

Parameter	Min	Typ	Max	Units
V <sub>CC</sub> (no damage)	-0.3		8	V
V <sub>LS</sub> (no damage)	-0.3		6	V
Operating Temperature Range	-20		85	°C
Storage Temperature Range	-55		150	°C
Electrostatic Discharge (ESD) Protection	2			kV

### Electrical Characteristics

V<sub>CC</sub>=1.5V, T<sub>a</sub> = 25°C, 10-14.7µH: one white LED / 4.7-6.8µH: two white LEDs in parallel, unless otherwise noted.

Parameter	Conditions	Min	Typ	Max	Units	
Supply Voltage, min. operating min. startup max. operating	L1 = 10...14.7µH T <sub>a</sub> = 25°C		0.70	0.80	V	
		1.90	0.90	0.95	V	
					V	
Supply Voltage, min. operating min. startup max. operating	L1 = 10...14.7µH T <sub>a</sub> = 0...60°C		0.80	0.90	V	
		1.90	1.00	1.05	V	
					V	
LED Mean Current (at V <sub>LS</sub> < V <sub>off</sub> ) measured with L1 type LQH32CN Murata	L1 = 22µH		12		mA	
	L1 = 14.7µH		15		mA	
	L1 = 10µH		23		mA	
	L1 = 6.8µH		32		mA	
	L1 = 4.7µH		40		mA	
Switching Current at V <sub>out</sub>	V <sub>out</sub> = 0.4V	250			mA	
Switching Frequency			500		kHz	
Threshold V <sub>off</sub> at LS *)	V <sub>CC</sub> > 950mV T <sub>a</sub> = 25°C T <sub>a</sub> = 0...60°C		0.27		V	
		0.26		0.28	V	
Threshold V <sub>on</sub> at LS *)	V <sub>CC</sub> > 950mV T <sub>a</sub> = 25°C T <sub>a</sub> = 0...60°C		0.22		V	
		0.21		0.23	V	
Quiescent supply current	V <sub>LS</sub> > V <sub>off</sub> *	V <sub>CC</sub> > 850mV		100	µA	
		V <sub>CC</sub> = 600mV		50	µA	
		V <sub>CC</sub> = 400mV		< 10	µA	
	V <sub>LS</sub> < V <sub>on</sub> *	V <sub>CC</sub> > 850mV		8		mA
		V <sub>CC</sub> = 600mV		100		µA
		V <sub>CC</sub> = 400mV		< 10		µA
Input resistance of LS input series resistor R1 resistor to Gnd R2			30		kΩ	
			400		kΩ	
Internal reference (bandgap) V <sub>ref</sub>			200		mV	
Efficiency			80		%	
V <sub>out</sub>				15	V	

\*) all data are preliminary

## Typical Characteristics

### Test circuit

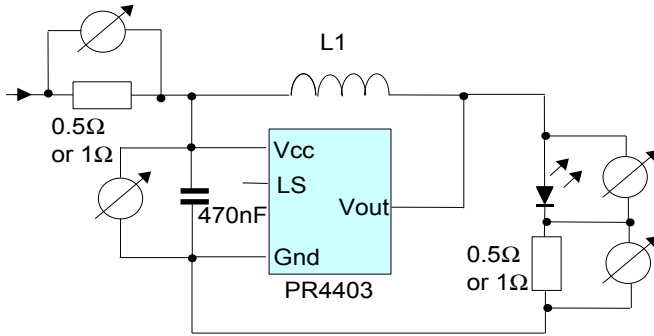

Measurement and Calculation of Efficiency

$$Efficiency (\%) = \frac{\frac{1}{T} \int_0^T (V_{LED} \cdot I_{LED}) dt}{\frac{1}{T} \int_0^T (V_{in} \cdot I_{in}) dt} \cdot 100$$

Depending on test setup and measuring method, efficiency values can vary by approx.  $\pm 5\%$ , and peak current values can vary by up to  $\pm 20\%$ , Accuracy of mean currents:  $\pm 1\text{mA}$ .  
Measuring conditions for all diagrams, unless otherwise noted:

- $T_a = 25^\circ\text{C}$
- one LED connected (peak voltage 4.2...5.8V)

A LQH32CN from Murata has been used as reference inductor, the DC resistance is specified as  $0.44 \Omega \pm 30\%$  for  $10 \mu\text{H}$  (max current 300 mA),  $0.71 \Omega \pm 30\%$  for  $22 \mu\text{H}$  (max. current 250 mA) and  $1.30 \Omega \pm 30\%$  for a  $47 \mu\text{H}$  inductor (max. current 170 mA). The LS pin is not connected.

## Oscilloscope Displays

LED voltage (CH1) and LED current (CH2, over 0.5 Ohm resistor)

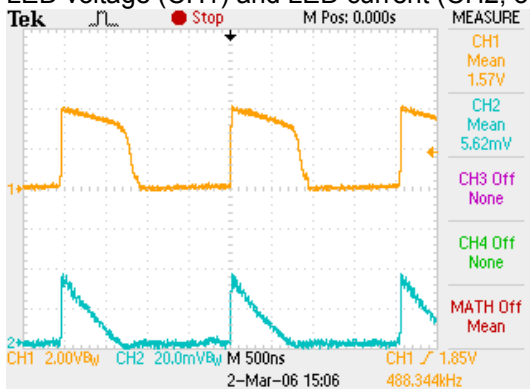

with  $L1 = 14.7 \mu\text{H}$

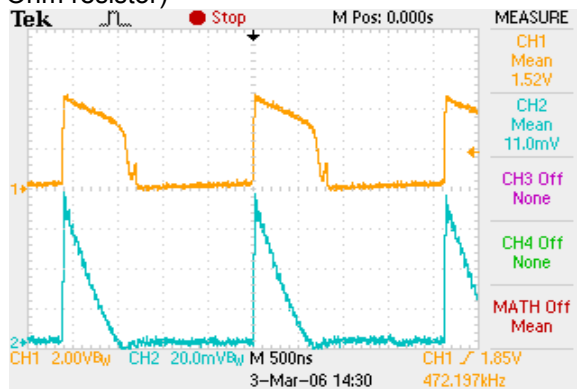

$L1 = 10 \mu\text{H}$

## PR4403 data

### Mean LED Current vs. Supply Voltage

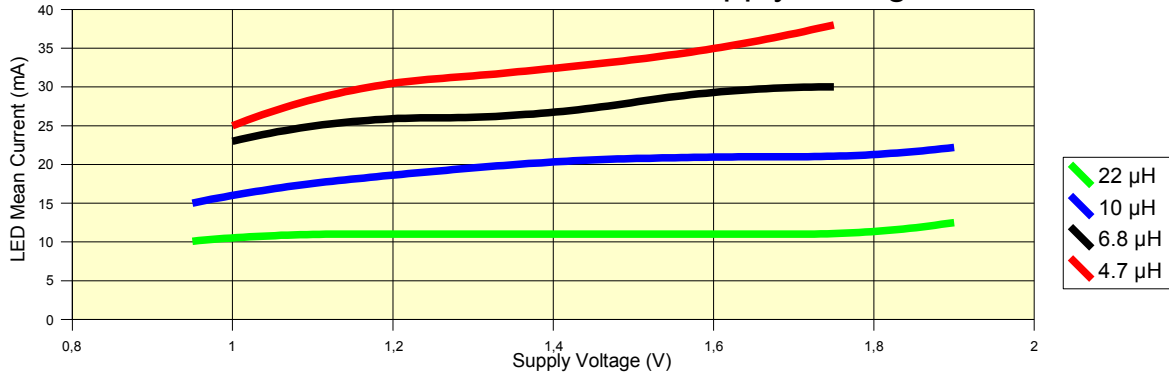

### Efficiency vs. Supply Voltage

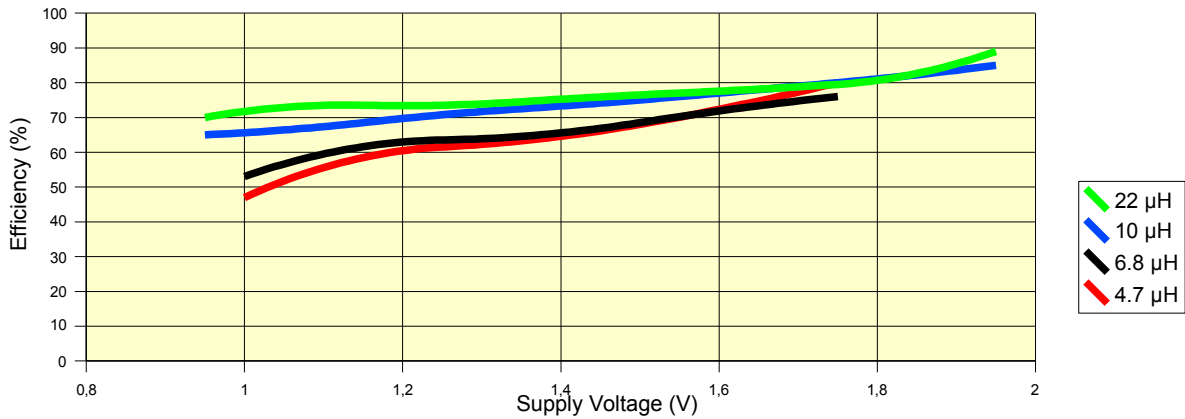

### Peak LED Current vs. Supply Voltage

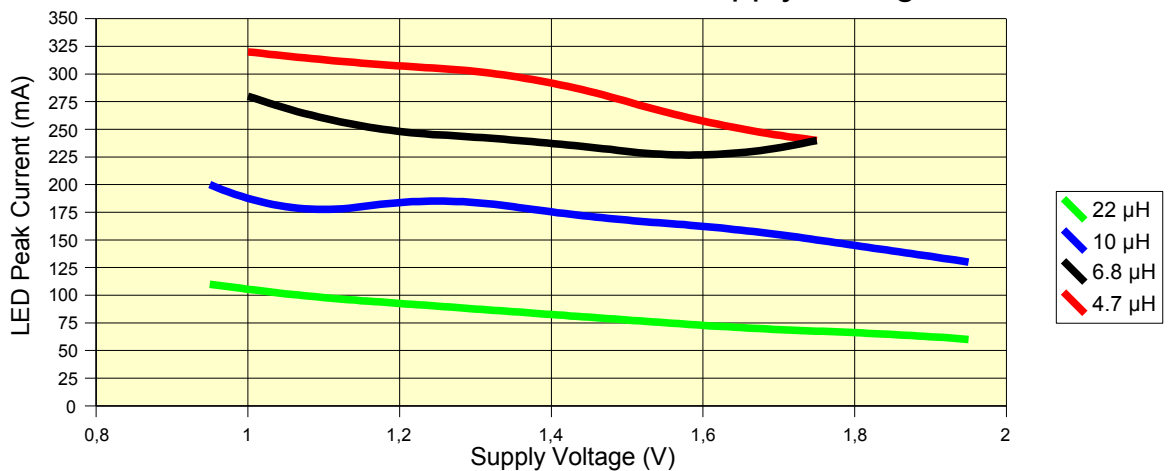

## Application Notes

### Use of the PR4403 in a solar garden lamp

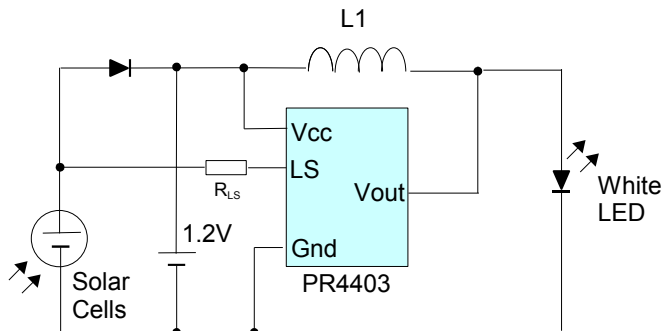

#### Solar cell as a battery charger and light sensor

The PR4403 offers good properties to realize a step-up driver for one white LED powered by only one rechargeable 1.2V battery cell charged by a 2.4V solar cell. The diode is recommended to be a 1N5158 Schottky diode. No additional photo sensor is required as the solar cell operates here as a light sensor. The resistor  $R_{LS}$  determines the light threshold at which the LED is automatically switched on (see Threshold voltage  $V_{ON}$  and  $V_{OFF}$  in „Electrical Characteristics“). A typical value of  $R_{LS}$  when using a solar cell is  $1.2M\Omega$ .

The resistor on the LS pin can be replaced by a photo resistor (for example a CDS resistor) instead of using the solar cell as light sensor.

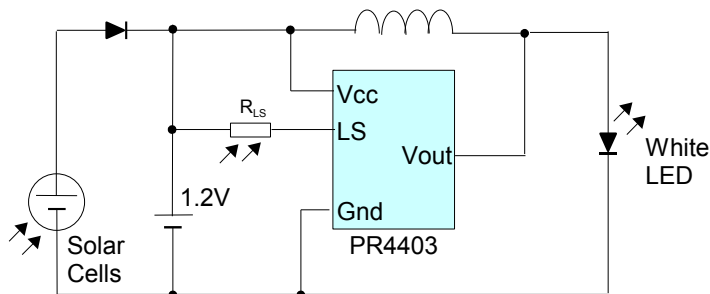

#### Photo resistor $R_{LS}$ works as a light sensor

Depending on the light resistance of the photo sensor an additional series resistor can be connected to the LS pin.

### Increasing the threshold voltage at the LS pin

A series resistor can be used in case that a higher threshold voltage ( $V_{ON}$ ) is necessary at the LS pin. The resistor can be calculated as follows:

$$R_{LS} = \frac{V_{ON} \cdot R2}{V_{ref}} - (R1 + R2) \quad \text{with}$$

R1, R2 and Vref specified in the „Electrical Characteristics“

$V_{ON}$ : desired threshold voltage

$R_{LS}$ : external resistor on the LS pin

For example:

A threshold voltage of 1V is desired.

$$\begin{aligned} R_{LS} &= 1V \cdot 400k\Omega / 200mV - (30k\Omega + 400k\Omega) \\ &= 1.57 M\Omega \end{aligned}$$

The following table defines the series resistor at LS

Threshold $V_{ON}$	$R_{LS}$
1.9 V	3.3 M $\Omega$
1 V	1.5 M $\Omega$
0.72 V	1 M $\Omega$
0.4 V	390 k $\Omega$

### Selection of inductors for PR4403

The inductor should be selected according to the required LED current.

Using lower inductances than specified may lead to erratic behaviour, especially at low supply voltages and should be avoided. Operating with higher inductances is possible and will lead to lower supply and LED current.

However the quiescent current which is independent of the inductance will lead to a lower overall efficiency.

While the series resistance of the coil has a small impact on the LED current, it is important that the saturation current is higher than the maximum peak current over the supply voltage range. Inductors optimized for DC-DC converters are mostly suitable.

### LED compatibility

In the simplest circuits with the lowest parts count shown above (or without smoothed current, see below) the peak current through the LED is a factor of up to 7 higher than the mean current. LED lifetime may be affected if operated outside the range specified by the LED vendor, but will most likely still be much longer than the lifetime of the rechargeable battery.

Since the emission spectrum of white LEDs usually depends on the current, the light color may shift to blueish white. High peak currents may also saturate the LED and reduce the light efficiency of the LED.

If the rated LED peak current is exceeded, it is recommended to use a smoothing capacitor and diode to provide a continuous output current (see below „Operation of LED with smoothed current (rectifier)“). With most standard LEDs, this will improve the overall performance with inductors of 10 $\mu$ H and less, or mean output currents of 23mA and more. Note that with the higher currents of PR4403 the current rating of standard LEDs might be exceeded, and more powerful or multiple LEDs should be used.

### Connection from Battery

Due to high peak currents, it is important to connect the PR4403 to the battery with short, low resistance wires, to achieve the best performance. A voltage drop along the wire affects LED current, efficiency and minimum startup and operating voltage.

This is most critical for applications with low inductivity and high current.

In cases where a longer wire from the battery cannot be avoided, a capacitor should be placed close to the Vcc and Gnd pin of PR4403. Typically a few 100nF will be enough. Operating at higher currents, a blocking capacitor is usually necessary even if wires or board layout are optimized.

### Using Different Battery Types

The input voltage must be 1.90V at maximum. At higher voltages the circuit may not trigger and start up correctly. Therefore operation with one Alkaline, NiCd, or NiMH cell (AA or AAA type) is recommended.

Alkaline button cells can also be used for supply. However, since high peak currents are drawn from the battery, button cells are recommended only with inductors of 22 $\mu$ H or more, depending on the battery type. A capacitor at the supply pins of PR4403 may also improve performance with button cells.

Lithium batteries are not suitable due to their higher voltage.



Approximate Lighting Duration with Alkaline battery:

<b>Battery</b>	<b>Lighting Duration, typical</b> <i>L1= 14.7μH, LED mean current 15mA</i>	<b>Lighting Duration, typical</b> <i>L1= 10μH, LED mean current 23mA</i>
AA (Mignon, LR 6/AM-3)	40 h	27 h
AAA (Micro, LR 03/AM-4)	16 h	8 h

Conditions: one white LED connected, measured with single 1.5V TDK Alkaline battery. Battery lifetime depends on battery capacity and operating conditions. Therefore the times indicated here can only give a rough indication of achievable times.

### Connecting several LEDs in parallel

When several LEDs are connected in parallel, it is necessary to match the forward voltage of these LEDs, to achieve a uniform brightness. The total current of all LEDs together corresponds approximately to the mean output current for operation with one LED.

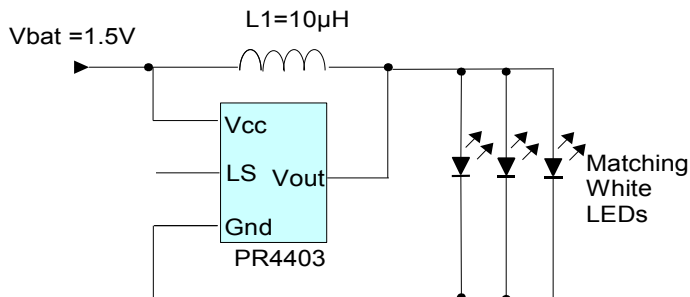

### Operation of LED with smoothed current (rectifier)

With a diode (preferably a Schottky diode) and a smoothing capacitor the voltage at the LED can be buffered. Output current and efficiency are typically higher than without capacitor, especially in the high-current range, due to different load characteristics. The capacitance must be small enough so that the voltage at the capacitor will exceed a voltage of 2.5V in the first cycle, otherwise the circuit may not start up. In most cases, values between 100nF and 1µF are appropriate.

The LS pin is not connected or connected to a light sensor (see above).

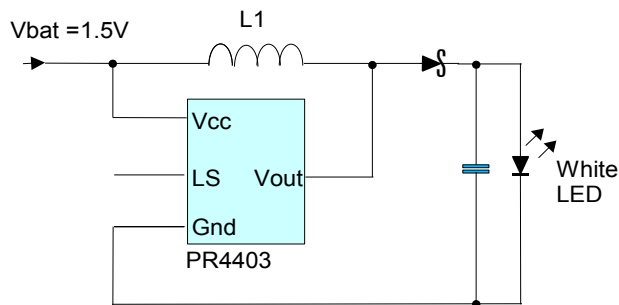

### Connecting two LEDs in series

It is possible to operate PR4403 with two LEDs in series at the output.

However, while the peak output current is nearly independent of the output load, the mean output current with two LEDs in series is reduced to half the current with one LED. In addition, at high output voltages the efficiency drops significantly, depending on operating conditions, and current pulses become shorter and sharper.

Therefore, although possible and useful in some cases, this operation mode is not recommended for general applications and not specified further.

### Using red, green or yellow LEDs

Although PR4403 is optimized for operation with white or blue LEDs, it will usually also work with red, green or yellow LEDs, with the following restrictions:

- The LED must build up a sufficient forward voltage to trigger PR4403. Due to the internal resistance of the LED, this condition is usually met. However, no guarantee can be assumed for proper operation under all conditions, and you need to qualify the system yourself
- Due to the different forward voltage level and internal resistance of colored LEDs, the timing is different, and mean currents are mostly lower than for white LEDs. Also other parameters may deviate from this data sheet.

## Available Package

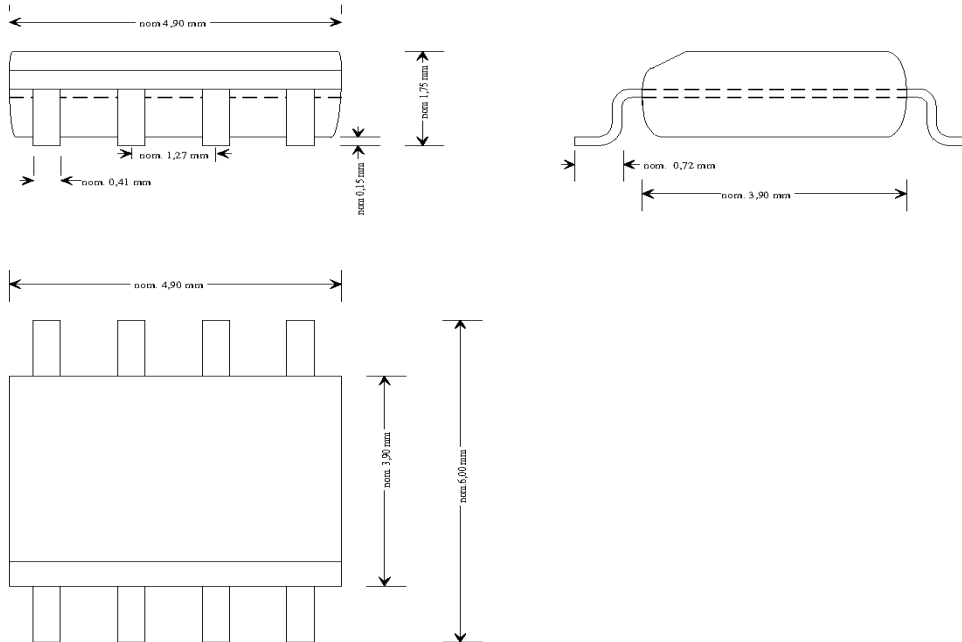

### PR4403 SO8 package in plastic tubes

All parts delivered comply with RoHS. Finish is pure tin.



Pb-free



pure tin

### **Disclaimer**

Information provided by PREMA is believed to be accurate and correct. However, no responsibility is assumed by PREMA for its use, nor for any infringements of patents or other rights of third parties which may result from its use. PREMA reserves the right at any time without notice to change circuitry and specifications.

### **Life Support Policy**

PREMA Semiconductors products are not authorized for use as critical components in life support devices or systems without the express written approval of PREMA Semiconductor. As used herein:

1. Life support devices or systems are devices or systems which, (a) are intended for surgical implant into the body, or (b) support or sustain life, and whose failure to perform when properly used in accordance with instructions for use provided in the labeling, can be reasonably expected to result in a significant injury to the user.
2. A critical component is any component of a life support device or system whose failure to perform can be reasonably expected to cause the failure of the life support device or system, or to affect its safety or effectiveness.

### **PREMA Semiconductor GmbH**

Robert-Bosch-Str. 6

55129 Mainz Germany

Phone: +49-6131-5062-0

Fax: +49-6131-5062-220

Email: [prema@prema.com](mailto:prema@prema.com) Web site: [www.prema.com](http://www.prema.com)